

UPDATE NOTICE #1

TSV05 TAPE TRANSPORT SUBSYSTEM USER'S GUIDE

Order No. EK-TSV05-UG-CN1

April 1983

Insert this Update Notice page in the manual as a means of maintaining an up-to-date record of changes to the manual.

NEW AND CHANGED INFORMATION

The TSV05 Tape Transport Subsystem was previously available only in cabinet-mounted models. The cabinets were shipped with the leveling feet in the parts envelope. As of this date, the product is available in both the cabinet model (TSV05-B) and a model intended for rack mounting in a customer-supplied cabinet (TSV05-A). Also, the cabinet model is now shipped with the leveling feet installed on the cabinet. This update changes the unpacking and installation instructions as required for the new model and the new shipping configuration. It also revises the product specifications to include the new model. Changes or additions are indicated by change bars in the outside margins. Deletions are indicated by bullets in the outside margins.

Copyright © 1983 Digital Equipment Corporation

The following pages are to be placed in the TSV05 Tape Transport Subsystem User's Guide as replacements for, or additions to, current pages.

<u>Old Page</u>	<u>New Page</u>
iii through vii	iii through vii
1-1 through 1-4	1-1 through 1-4
1-9 through 1-12	1-9 through 1-12
2-1 through 2-18	2-1 through 2-18
2-23 through 2-24	2-23 through 2-24
2-31 through 2-32	2-31 through 2-32
3-11 through 3-12	3-11 through 3-12
3-25 through 3-26	3-25 through 3-26
3-45 through 3-46	3-45 through 3-46
	D-1 through D-4
	E-1 through E-3



CONTENTS

	Page
CHAPTER 1	INTRODUCTION
1.1	PURPOSE AND SCOPE.....1-1
1.2	GENERAL DESCRIPTION.....1-1
1.2.1	Features and Capabilities.....1-3
1.2.2	Functional Overview.....1-5
1.2.3	Controls and Indicators.....1-6
1.3	PHYSICAL DESCRIPTION.....1-9
1.3.1	Mechanical Characteristics.....1-9
1.3.2	Electrical Requirements.....1-9
1.3.3	Environmental Considerations.....1-10
1.3.3.1	Operating Conditions.....1-10
1.3.3.2	Nonoperating Conditions.....1-11
1.3.3.3	Emissions.....1-11
1.4	RELATED DOCUMENTS.....1-12
CHAPTER 2	INSTALLATION
2.1	SITE PREPARATION.....2-1
2.1.1	Accessibility.....2-2
2.1.2	Power Receptacles.....2-2
2.1.3	Cooling.....2-2
2.1.4	Air Purity.....2-4
2.2	UNPACKING AND INSPECTION.....2-4
2.2.1	Tools and Working Space.....2-4
2.2.2	Unpacking the Cabinet.....2-4
2.2.3	Deskidding the Cabinet.....2-6
2.2.4	Unpacking the Smaller Cartons.....2-9
2.3	TAPE TRANSPORT CABINET INSTALLATION.....2-10
2.3.1	Tools Required.....2-10
2.3.2	Moving the Side Panel.....2-10
2.3.3	Connecting the H9642 Cabinets.....2-15
2.3.4	Removing Shipping Foam.....2-18
2.3.4.1	Removing the Top Foam Pieces.....2-18
2.3.4.2	Removing the Bottom Foam Pieces.....2-18
2.3.5	Connecting Line Power.....2-23
2.4	TAPE TRANSPORT CHECKOUT.....2-24
2.4.1	Power Up Test.....2-24
2.4.2	Tape Loading Test.....2-25
2.4.3	Tape Movement Test.....2-27
2.4.4	Tape Unloading Test.....2-28
2.5	BUS INTERFACE/CONTROLLER MODULE INSTALLATION.....2-28
2.6	CABLE INSTALLATION.....2-29
2.6.1	M7196 Module and Tape Transport Interconnection.....2-29
2.6.2	Power Controller Interconnection (Supplied With TSV05-B Models Only).....2-31
2.7	TSV05 SUBSYSTEM CHECKOUT.....2-32
2.7.1	Power Up Checks.....2-32

CONTENTS (Cont)

	Page
2.7.2	System Setup.....2-33
2.7.3	TSV05 Logic Test.....2-33
2.7.4	Advanced Logic Test.....2-35
2.7.5	Tape Transport Test.....2-35
2.7.6	Advanced Tape Transport Test.....2-36
2.7.7	Data Reliability Test.....2-36
2.7.8	Additional Testing.....2-37

CHAPTER 3 OPERATION

3.1	ROUTINE OPERATING PROCEDURES.....3-1
3.1.1	Power Up.....3-1
3.1.2	Loading Tape.....3-1
3.1.3	Rewinding Tape.....3-2
3.1.4	Unloading Tape.....3-4
3.1.5	Restarting the Tape Subsystem.....3-4
3.1.5.1	Power Failure.....3-4
3.1.5.2	Hard Errors.....3-4
3.1.6	Operator Troubleshooting.....3-5
3.1.7	Confidence Checks.....3-5
3.1.8	Customer Case.....3-6
3.1.8.1	Case of Magnetic Tape.....3-6
3.1.8.2	Preventive Maintenance.....3-7
3.2	TSV05 OPERATIONS.....3-12
3.3	PROGRAMMING.....3-12
3.3.1	Overview.....3-13
3.3.2	Registers.....3-18
3.3.2.1	Bus Address Register (TSBA).....3-18
3.3.2.2	Data Buffer Register (TSDB).....3-20
3.3.2.3	Status Register (TSSR).....3-22
3.3.2.4	Extended Data Buffer Register (TSDBX).....3-26
3.3.2.5	Extended Status Register 0 (XST0).....3-27
3.3.2.6	Extended Status Register 1 (XST1).....3-30
3.3.2.7	Extended Status Register 2 (XST2).....3-32
3.3.2.8	Extended Status Register 3 (XST3).....3-34
3.3.2.9	Extended Status Register 4 (XST4).....3-35
3.3.2.10	Summary of Registers.....3-37
3.3.3	Packet Processing.....3-39
3.3.3.1	Buffer Ownership and Control.....3-40
3.3.3.2	Buffer Control on Attentions.....3-42
3.3.3.3	Message Packet Format.....3-44
3.3.3.4	General Status Handling Information.....3-47
3.3.4	COMMANDS.....3-53
3.3.4.1	Command Packet Definitions.....3-54
3.3.4.2	Get Status Command.....3-60
3.3.4.3	Read Command.....3-60
3.3.4.4	Write Characteristics Command.....3-63
3.3.4.5	Write Command.....3-69

CONTENTS (Cont)

	Page
3.3.4.6	Position Command.....3-70
3.3.4.7	Format Command.....3-72
3.3.4.8	Control Command.....3-73
3.3.4.9	Inititalize Command.....3-74
3.3.4.10	Write Subsystem Memory Command.....3-74
3.3.5	Record Buffering.....3-75
3.3.5.1	Read Buffering.....3-75
3.3.5.2	Write Buffering.....3-78

APPENDIX A CONFIGURATION DATA

APPENDIX B MANUAL LOADING

APPENDIX C SUMMARY OF KNOWN DIFFERENCES

APPENDIX D TSV05-A RACK MOUNTING GUIDELINES

APPENDIX E H9612 TO H9642 CABINET INTERCONNECTION

FIGURES

Figure No.	Title	Page
1-1	TSV05 Subsystem Components.....	1-2
1-2	Operator Front Panel.....	1-7
2-1	Cabinet Access Requirements.....	2-3
2-2	Cabinet Carton Removal.....	2-5
2-3	Cabinet Shipping Brackets.....	2-6
2-4	Raising Leveling Feet.....	2-7
2-5	Deskidding the Cabinet.....	2-8
2-6	Opening Cabinet Door.....	2-9
2-7	H9642 Tape Transport Cabinet Connection.....	2-11
2-8	Removing Side Panel.....	2-12
2-9	Mounting the Side Panel.....	2-14
2-10	Cabinet Alignment.....	2-16
2-11	H9642 Cabinet Interconnection Hardware.....	2-17
2-12	Cabinet Top Cover.....	2-19
2-13	Tape Transport Top Cover.....	2-20
2-14	Tachometer and Takeup Hub.....	2-21
2-15	Service Access Position.....	2-22
2-16	Front Panel Controls and Indicators.....	2-24
2-17	Inserting Tape.....	2-26
2-18	Cabling the M7196 Module.....	2-30
2-19	Cabling the Tape Transport.....	2-30
2-20	Remote Power Control Connections.....	2-31
3-1	Opening the Front Door Panel.....	3-3
3-2	Accessing the Tape Path Area.....	3-10

FIGURES (Cont)

Figure No.	Title	Page
3-3	Tape Path and Related Parts.....	3-11
3-4	Command Packet Types.....	3-17
3-5	TSBA Register Format.....	3-19
3-6	TSDB Register Format.....	3-21
3-7	TSSR Register Format.....	3-22
3-8	TSDBX Register Format.....	3-26
3-9	XST0 Register Format.....	3-27
3-10	XST1 Register Format.....	3-30
3-11	XST2 Register Format.....	3-32
3-12	XST3 Register Format.....	3-34
3-13	XST4 Register Format.....	3-35
3-14	TSV05 Hardware Device Registers.....	3-37
3-15	TSV05 Extended Status Registers.....	3-38
3-16	TSV05 Command Register Format.....	3-39
3-17	Message Packet Format.....	3-44
3-18	Command Packet Header Word.....	3-54
3-19 (a)	Memory/Tape Data Byte Positioning (Forward Tape Direction, Read or Write; Reverse Read with Even Byte Count).....	3-58
3-19 (b)	Memory/Tape Data Byte Positioning (Forward or Reverse Read, Odd Byte Count).....	3-59
3-20	Get Status Command Packet.....	3-60
3-21	Read Command Packet.....	3-61
3-22	Write Characteristics Command Format.....	3-65
3-23	Write Command Packet.....	3-69
3-24	Position Command Packet.....	3-71
3-25	Format Command Packet.....	3-72
3-26	Control Command Packet.....	3-73
3-27	Initialize Command Packet.....	3-74
A-1	M7196 Switch and Jumper Identification.....	A-1
A-2	M7196 Vector and Address Switches.....	A-2
A-3	Transport Switch and Terminator Identification....	A-3
B-1	Accessing the Tape Path Area.....	B-2
B-2	Tape Threading Path.....	B-3
D-1	TSV05-A Mounting Requirements.....	D-2
D-2	Chassis Slide Mounting.....	D-3
E-1	Cabinet Interconnection.....	E-2

TABLES

Table No.	Title	Page
1-1	Controls and Indicators.....	1-7
2-1	Power Line Connections.....	2-2
2-2	TSV05 Subsystem Diagnostics.....	2-32
3-1	Suggested Preventive Maintenance Schedule.....	3-8
3-2	TSV05 Assigned Command Modes.....	3-14

TABLES (Cont)

Table No.	Title	Page
3-3	TSBA Register Bit Definitions.....	3-19
3-4	TSDB Register Bit Definitions.....	3-21
3-5	TSSR Register Bit Definitions.....	3-22
3-6	TSDBX Register Bit Definitions.....	3-27
3-7	XST0 Register Bit Definitions.....	3-28
3-8	XST1 Register Bit Definitions.....	3-31
3-9	XST2 Register Bit Definitions.....	3-33
3-10	XST3 Register Bit Definitions.....	3-34
3-11	XST4 Register Bit Definitions.....	3-36
3-12	Buffer Ownership Transfers.....	3-40
3-13	Message Packet Field Definitions.....	3-45
3-14	Termination Class/Message Type Relationship.....	3-48
3-15	Command Packet Header Word Bit Definitions.....	3-55
3-16	Command Code and Mode Field Definitions.....	3-57
3-17	Characteristic Mode Data Word Bit Definitions.....	3-66
3-18	Extended Characteristics Data Word Bit Definition.....	3-67

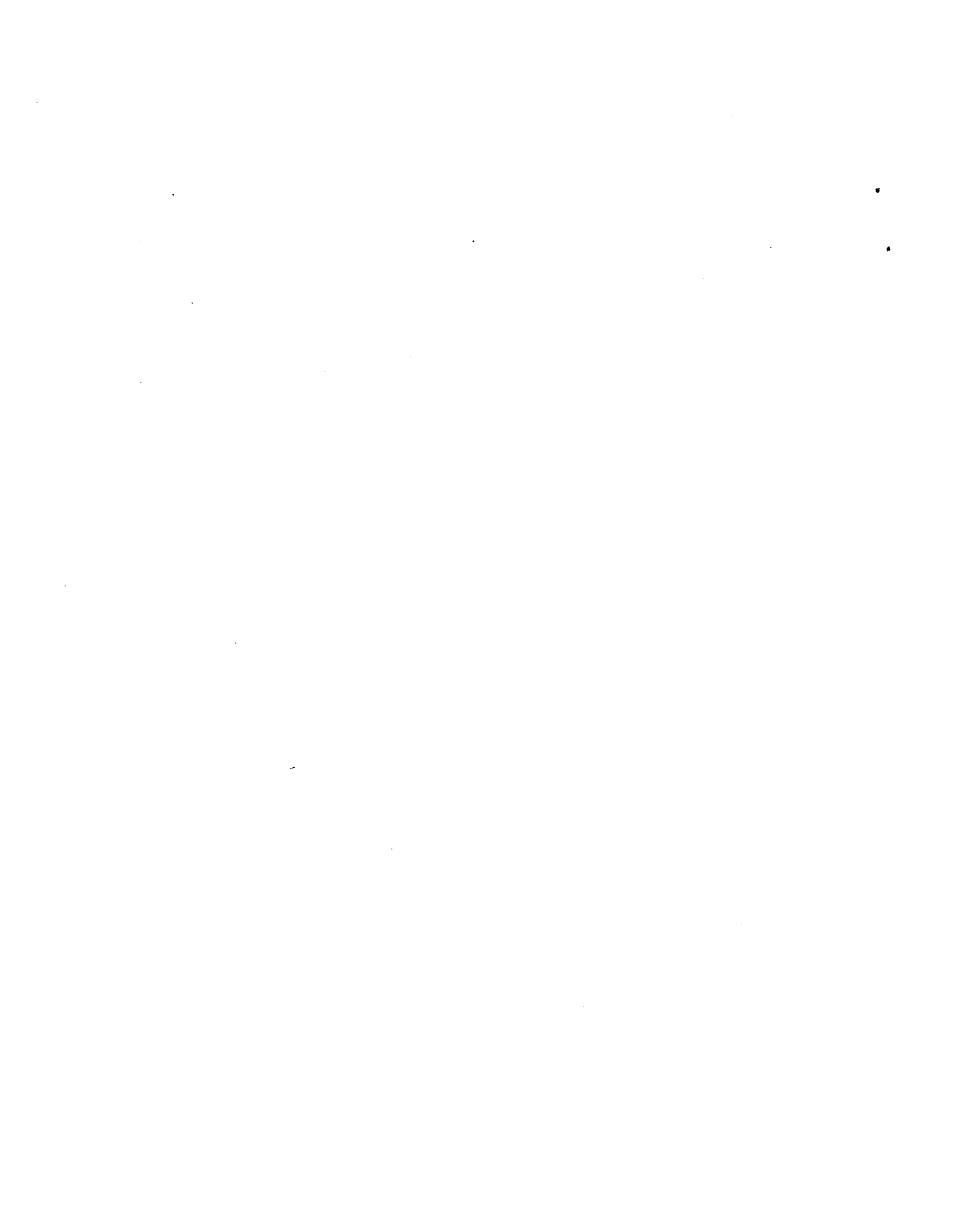

1.1 PURPOSE AND SCOPE

This manual describes how to unpack, install, and check out the TSV05 Tape Transport Subsystem. It also describes the capabilities and basic functions of the subsystem. An overview of the functional characteristics and the physical specifications appears in Chapter 1, while Chapter 2 is devoted to the installation. Chapter 3 discusses various aspects of system operation, including routine operating procedures and programming requirements. For further information, refer to the documents listed in Section 1.4.

1.2 GENERAL DESCRIPTION

The TSV05 Tape Transport Subsystem provides magnetic tape storage capabilities to computer systems using quad-sized LSI-11 bus backplanes. The subsystem reads or writes up to 160,000 bytes per second in ANSI standard format. Data is recorded by phase encoding 1600 bits per inch on nine-track tape. Reading and writing are performed at either 25 or 100 inches per second.* The TSV05 subsystem is hardware compatible with 18- and 22-bit addressing versions of the LSI-11 bus quad backplane. It is software compatible with system and application programs written for the TS11 tape transport subsystem (as long as such programs use the Digital supplied device handler). Tape formatting, error detection and correction, and self-test diagnostics are included as integral components of the TSV05 subsystem.

The TSV05-A hardware consists of:

1. TS05-A tape transport
2. M7196 LSI-11 bus interface/controller module
3. Pair of 7016855 bus cables for connecting tape transport input and output to the bus interface/controller module.

The TSV05-B includes these three items and also an H9642-series cabinet with an 874 power controller and a remote power control cable.

The bus interface/controller module plugs into the LSI-11 bus (see Figure 1-1). The two cables connect the module with the tape transport.

*100 inches per second operating speed requires enabling special features and the appropriate software.

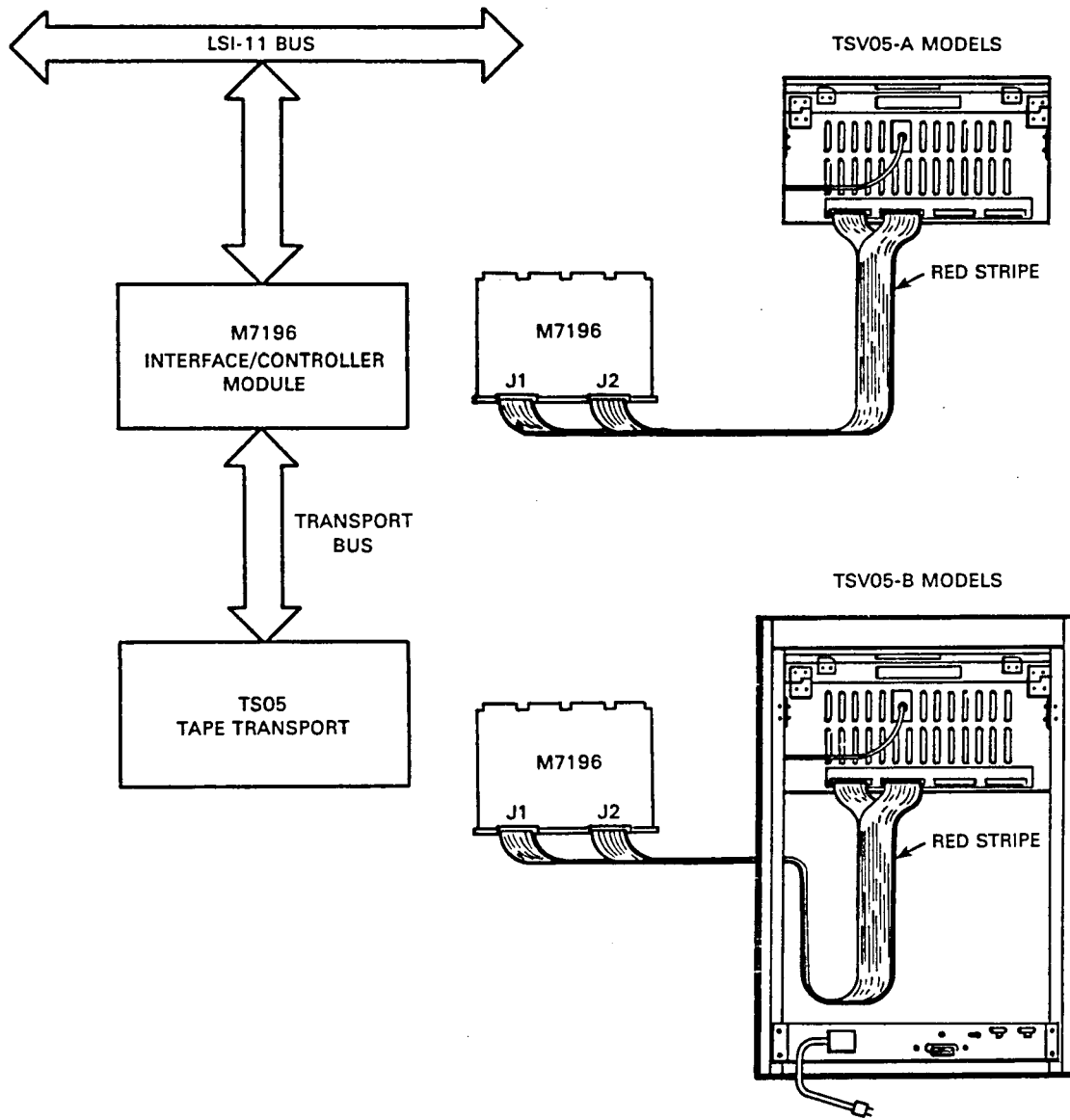

CS-2838

Figure 1-1 TSV05 Subsystem Components

1.2.1 Features and Capabilities

The TSV05 Tape Transport Subsystem offers the following:

- Bidirectional reading capability
- 3.5K bytes of RAM in controller for buffering tape data
- Streaming, or reel-to-reel, technology (meaning that the tape is not required to stop in the interrecord gap)
- Automatic tape loading (threading)
- Microprocessor control in both the controller and the tape transport
- Microcoded diagnostic and maintenance features
- Tape formatting and error detection following ANSI X 3.39-1973 Standard
- Both ANSI and IBM tape mark detection
- Industry standard bus between controller and tape transport
- On-line diagnostics that verify data path integrity during idle periods
- Uses media conforming to ANSI X 3.40-1976 Standard
- Automatic read after write verification
- Small form factor with low power consumptions.

The tape handling characteristics and parameters are as follows:

Tape Characteristics

Type:	Mylar base, iron-oxide coated
Length:	731 m (2400 ft) maximum
Width:	1.3 cm (0.5 in)
Thickness:	1.5 mil (industry compatible)
Reel Diameter:	26.7 cm (10.5 in) 2400 ft 21.6 cm (8.5 in) 1200 ft 17.8 cm (7.0 in) 600 ft
Capacity/Tape Reel:	46 million bytes (10.5 in reel, unformatted)

Tape Motion

Handling: Bidirectional reel-to-reel, with compliance arm

Tape Tension: 212.6 g (7.5 oz) nominal

Read/Write Speed: 64 cm/sec (25 in/sec) (using TS11 software)
64 or 254 cm/sec (25 or 100 in/sec) (program selectable using special software)

Rewind Speed: 330 to 457 cm/sec (130 to 180 in/sec) (nominal), depending on reel size
457 cm/sec (180 in/sec) (average), using 26.7 cm (10.5 in) reel

Rewind Time:

<u>Reel Size, cm (in)</u>	<u>Minutes, maximum</u>
17.8 (7.0)	0.9
21.6 (8.5)	1.6
26.7 (10.5)	2.8

Auto Loading

Reliability: An average of 96% of attempted loads will be successful, with automatic retries, assuming a properly maintained transport and tape library.

Retries: Three automatically provided.

Times: 30 sec typical with no retry
30 sec maximum for each additional retry

Unloading

Time: 15 sec maximum with tape located at BOT

Tape Speed Variation:

Long Term: $\pm 1\%$ of nominal
Instantaneous: $\pm 4\%$ of long term

Data Access Times:

	<u>64 cm/sec (25 in/sec)</u>	<u>254 cm/sec (100 in/sec)</u>
Tape at Rest:	40 ms	260 ms
Worst Case:	140 ms	1040 ms

1.3 PHYSICAL DESCRIPTION

1.3.1 Mechanical Characteristics

<u>Tape Transport Cabinet (TSV05-B)</u>	<u>Tape Transport (TSV05-A)</u>
Height: 111.13 cm (43.75 in)	22.23 cm (8.75 in)
Width: 59.69 cm (23.50 in)	48.26 cm (19.00 in)
Depth: 83.82 cm (33.00 in)	61.60 cm (24.25 in)
Weight: 121 kg (265 lb)	36 kg (80 lb)

M7196 Bus Interface/Controller Module

Length:	(From contact fingers to handles): 228.6 mm (9.0 in)
Width:	266.7 mm (10.5 in)
Thickness:	12.7 mm (0.5 in)
Weight:	0.51 kg (1.13 lb)

Formatter Bus Cables

Connectors:	50-pin, right-angle, flat cable header connectors at controller end; industry standard formatter connectors at tape transport end.
Length:	2.4 m (8.0 ft)

1.3.2 Electrical Requirements

<u>Tape Transport</u>	<u>Cabinet Power Control</u>
-----------------------	------------------------------

Power Consumption:	220 W average 270 W maximum	16.5 W maximum
--------------------	--------------------------------	----------------

AC Voltage (+7% or -15%):

	<u>Nominal</u>	<u>Low Limit</u>	<u>High Limit</u>
TSV05-AA, -BA	120	102	128
TSV05-AB, -BB	240	204	256
TSV05-AC	100	85	107
TSV05-AD, -BD	220	187	235

Frequency: \pm 1 Hz

<u>Nominal, Hz</u>	<u>Low Limit, Hz</u>	<u>High Limit, Hz</u>
50 or 60	49	61

Frequency Rate of Change: 1.5 Hz/sec maximum

M7196 Controller

Power Consumption: 5 Vdc \pm 5% at 6.5 A (maximum)

LSI-11 Bus Loading: DC: One load
AC: Three loads (maximum)

1.3.3 Environmental Considerations

Specifications presented in this section apply to the TSV05-B model. Specifications for the TSV05-A model may be affected by the cabinetry in which it is installed.

- 1.3.3.1 Operating Conditions -- The TSV05-B subsystem is designed to operate under the following conditions:

Temperature

15°C to 32°C (59°F to 90°F)

Temperature Shock: 20°C change/hr maximum

Relative Humidity

20% to 80% noncondensing

Altitude

Sea level to 3 km (10,000 ft)

Vibration

Frequency Range: 5 to 500 Hz

Peak Acceleration: 0.25 g, 22 to 500 Hz, 0.01 in DA5-22 Hz

Application: Each of three orthogonal axes

Shock

+10 g peak, Halfsine, 10 ms

Pollutants

Atmospheric Particulates: 60 mg/1000 cu ft air by weight of particle (5 micron diameter)

Electrostatic Discharge

10 kV through 100 ohms from 350 pF

1.3.3.2 Nonoperating Conditions -- The TSV05-B subsystem is designed to withstand the following conditions during nonoperating periods (e.g., shipping):

Temperature

-40°C to 66°C

Relative Humidity

95% maximum, noncondensing

Altitude

Sea level to 15 km (49,000 ft)

NOTE

Magtape media typically has more restricting nonoperating environmental considerations.

Vibration (in shipping container)

Frequency Range: 10 to 300 Hz

Peak Acceleration: 1.4 g rms vertical axis

0.68 g rms longitudinal and lateral axis
200 Hz maximum

Shock (in shipping container)

Peak Acceleration: 20 g

Duration: 30 ± 10 ms

Waveshape: 1/2 sine

1.3.3.3 Emissions -- During normal operation, the TSV05-B subsystem is designed to emit no more than the following levels:

Heat

1100 Btu/hr maximum

Acoustic Noise

Standby (blower on): 57 dB A scale

Operating Conditions: 60 dB A scale

Electromagnetic Interference (EMI)

The TSV05-B complies with FCC Part 15, Subpart J, Class A, and is designed to comply with VDE 0871 B requirements.

NOTE

The TSV05-B subsystem has been designed and tested to meet Digital standards including FCC requirements. The specifications in this chapter are based on this testing. Digital cannot guarantee the TSV05-B subsystem will meet these specifications if nontested equipment is installed into the TSV05-B cabinet or the TSV05-B cabinet is installed in nontested configurations. It is the responsibility of the end manufacturer to verify that TSV05-A configurations conform to the required safety and performance standards.

1.4 RELATED DOCUMENTS

Title	Order Number
<u>TSV05 Tape Transport Pocket Service Guide</u>	EK-TSV05-PS
<u>Operation and Maintenance Instructions for Model F880 Tape Transport</u>	799816-000*
<u>TSV05 Tape Transport Subsystem Installation Manual</u>	EK-TSV05-IN
<u>XXDP User Guide</u>	AC-90931-MC
<u>DEC/X11 User Document</u>	AC-8240Z-MC
<u>TS05 Tape Transport Operation and Acceptance Preventive Maintenance Remove/Replace</u>	EY-D3142-PS
<u>TSV05 Field Print Set</u>	MP-01157
<u>TSV05 Tape Transport Subsystem Technical Manual</u>	EK-TSV05-TM
<u>Microcomputers and Memories</u>	EB-18451-20
<u>Microcomputer Interfaces Handbook</u>	EB-17723-20

CAUTION

Reference the appropriate TSV05 Manual for installation, operation, and maintenance information.

*Available from Cipher Data Products, 10225 Willow Creek Road, San Diego, California 92131. This document contains detailed drawings of the TS05 formatter and power supply.

This chapter explains the TSV05 Tape Transport Subsystem installation. A section is devoted to each of the following:

1. Site preparation
2. Unpacking and inspection
3. Installing the tape transport cabinet
4. Checking out the tape transport
5. Installing the bus interface/controller module
6. Installing the interconnecting cables
7. Checking out the TSV05 subsystem.

NOTE

BEFORE YOU UNPACK the cartons, inspect for signs of shipping damage. If the shipment has been damaged, call the dealer from whom the equipment was purchased. If the equipment is covered under "Digital Transit Insurance", the Digital representative will estimate the damage and put in a claim. If the equipment is not insured by "Digital Transit Insurance", contact the carrier who handled the equipment and your own insurance company. Digital Field Service is available on a per-call basis to make estimates of damage for any resulting insurance claims.

2.1 SITE PREPARATION

The TSV05-B Tape Transport Subsystem mounts to the left side of the existing computer cabinet. It requires a 59.7 centimeter (23.5 inch) wide by 83.8 centimeter (33.0 inch) deep area of floor space that is capable of supporting, as a minimum, 121 kilograms (265 pounds). The cabinet is capable of supporting up to 205 kilograms (450 pounds). Refer to Appendix D for TSV05-A rack mounting guidelines.

Beyond this mounting space, the TSV05 subsystem also requires room for access to the cabinet, the correct power receptacle, and an adequate flow of cooling air.







2.1.1 Accessibility

The cabinet requires sufficient space behind it for opening the rear door. If any expansion is anticipated, room in front of the cabinet will be required to allow future equipment to be pulled out of the cabinet for maintenance. Refer to Figure 2-1 for required dimensions.

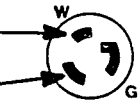
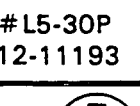
2.1.2 Power Receptacles

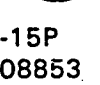
Ensure that the correct power receptacle is available (refer to Table 2-1). It should be capable of handling at least the 270 watts required by the tape transport.

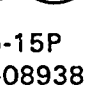
Table 2-1 Power Line Connections

MODEL	PLUG	RECEPTACLE	CIRCUIT RATING
TSV05-BA BUILT PRIOR TO FEB 1983	SILVER →  BRASS →  NEMA #L5-30P DEC #12-11193	 L5-30R 12-11194	120 V 24 A
TSV05-AB -AD TSV05-BB -BD	BRASS 2 →  BRASS 1 →  NEMA #6-15P DEC #90-08853	 6-15R 12-11204	220/240 V 12A
TSV05-AA -AC TSV05-BA	SILVER →  BRASS →  NEMA #5-15P DEC #90-08938	 5-15R 90-08939	100/120V 12A

CS-2839

Power Cord Color Code

Pin Connection

<u>Color</u>	<u>Function</u>	<u>L5-30P</u>	<u>6-15P</u>	<u>5-15P</u>
Brown	Hot	Brass	Brass 1	Brass
Blue	Neutral	Silver	Brass 2	Silver
Green/yellow	Ground	Ground	Ground	Ground

2.1.3 Cooling

The TSV05 subsystem requires 1100 Btu per hour of cooling to be provided by the movement of room air through the cabinet.

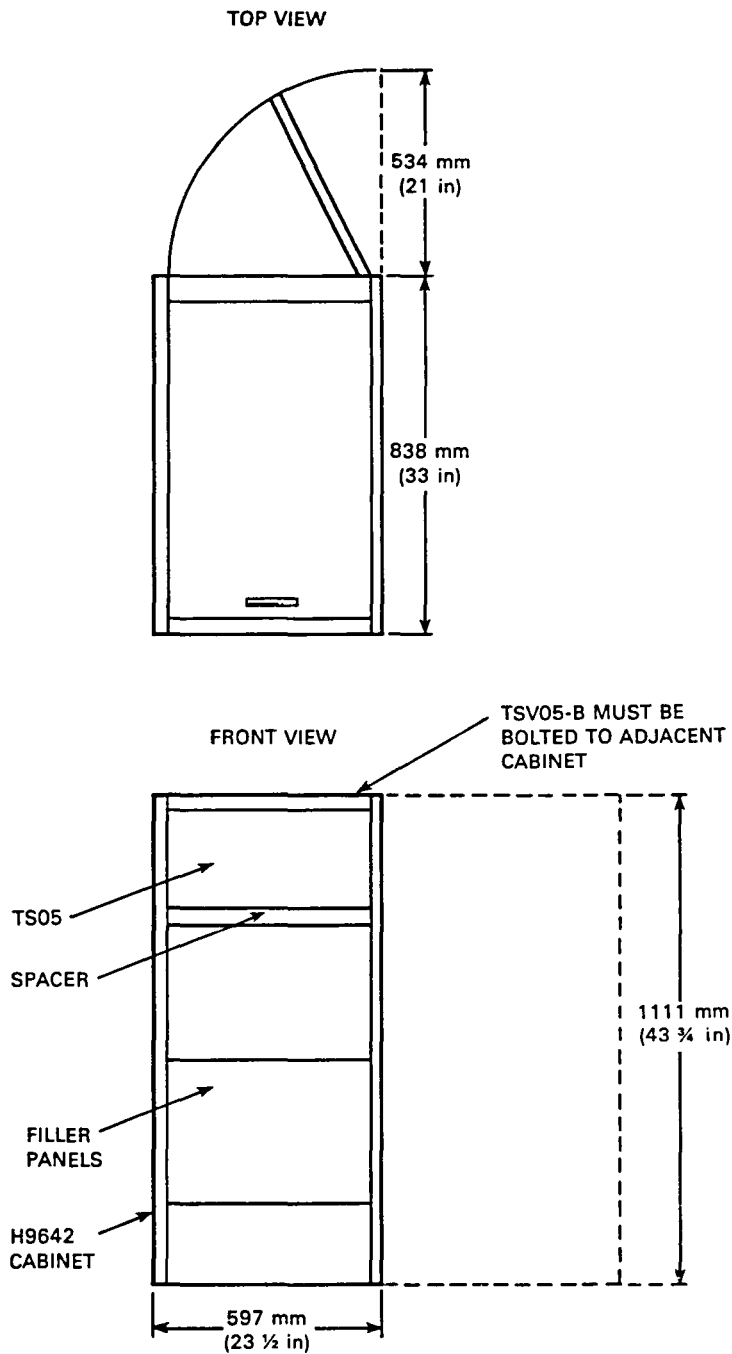

CS-2430

Figure 2-1 Cabinet Access Requirements

2.1.4 Air Purity

The tape transport is equipped with internal filters to prevent dust from accumulating on the tape and tape heads. Nevertheless, it is good practice to avoid placing the cabinet in the path of a dust-laden current of air (such as beside a door).

2.2 UNPACKING AND INSPECTION

The TSV05-A is shipped in one large carton and one or more small cartons. Refer to Appendix D for TSV05-A rack mounting guidelines.

The TSV05-B is shipped as one skid-mounted carton and one or more smaller cartons. The carton on the skid contains the TS05 tape transport cabinet. The smaller carton(s) contain the M7196 controller, the documentation and accessories, and two individually packaged cables. These smaller items may be shipped in one carton or two, depending on shipping requirements. Check the shipping documents to ensure that the correct model has been shipped. If anything is missing, damaged, or incorrect, contact the dealer from whom the equipment was ordered.

2.2.1 Tools and Working Space

The following tools are required for unpacking the TSV05 subsystem:

1. Scissors
2. 9/16 inch wrench
3. 11/16 inch wrench
4. 3/4 inch wrench
5. 5/32 inch hex key

Also, an area of approximately 3 meters (10 feet) square is required for moving the cabinet off the shipping skid.

2.2.2 Unpacking the Cabinet

1. Cut the nylon straps and remove the cardboard pieces of the cabinet carton as shown in Figure 2-2. Remove the plastic bag.
2. Using a 9/16 inch wrench, remove the four bolts that hold the cabinet to the skid (Figure 2-3).
3. Remove the metal hold-down brackets.
4. Using an 11/16 inch wrench, loosen the leveling feet locking nuts (Figure 2-4).

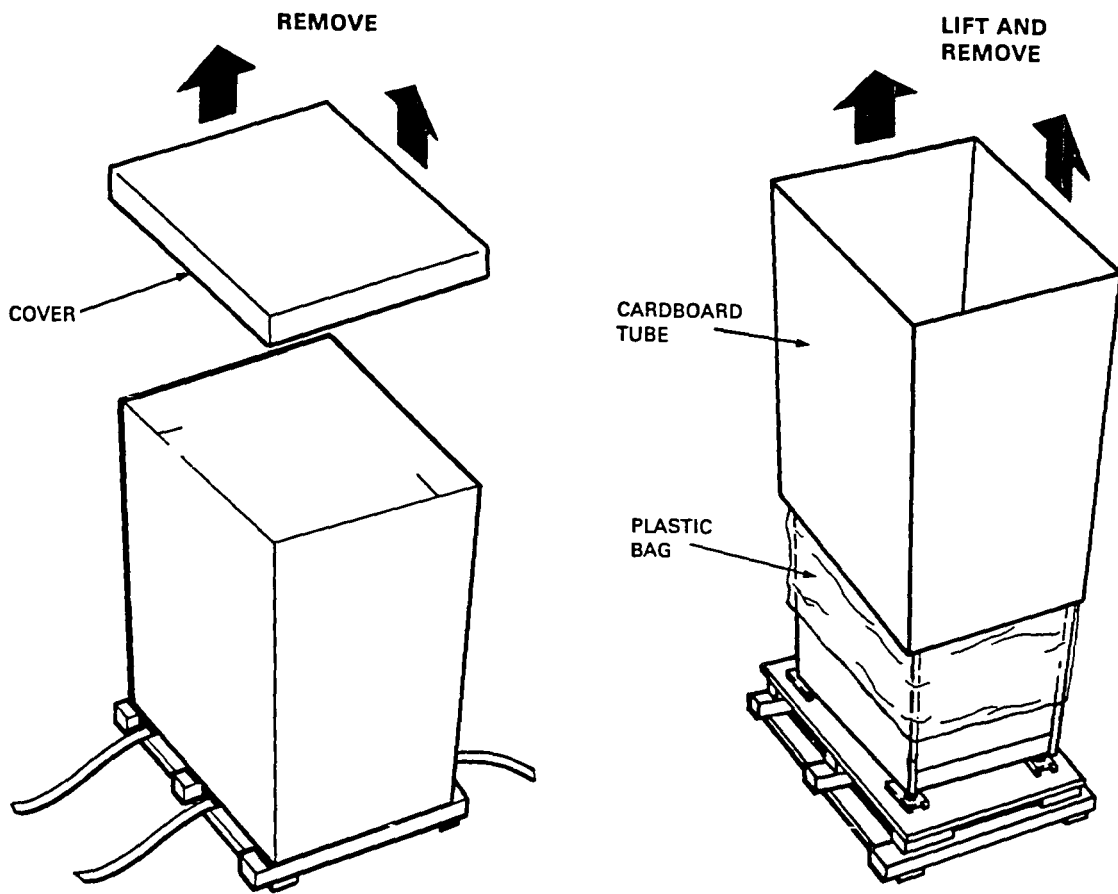

CS-2432

Figure 2-2 Cabinet Carton Removal

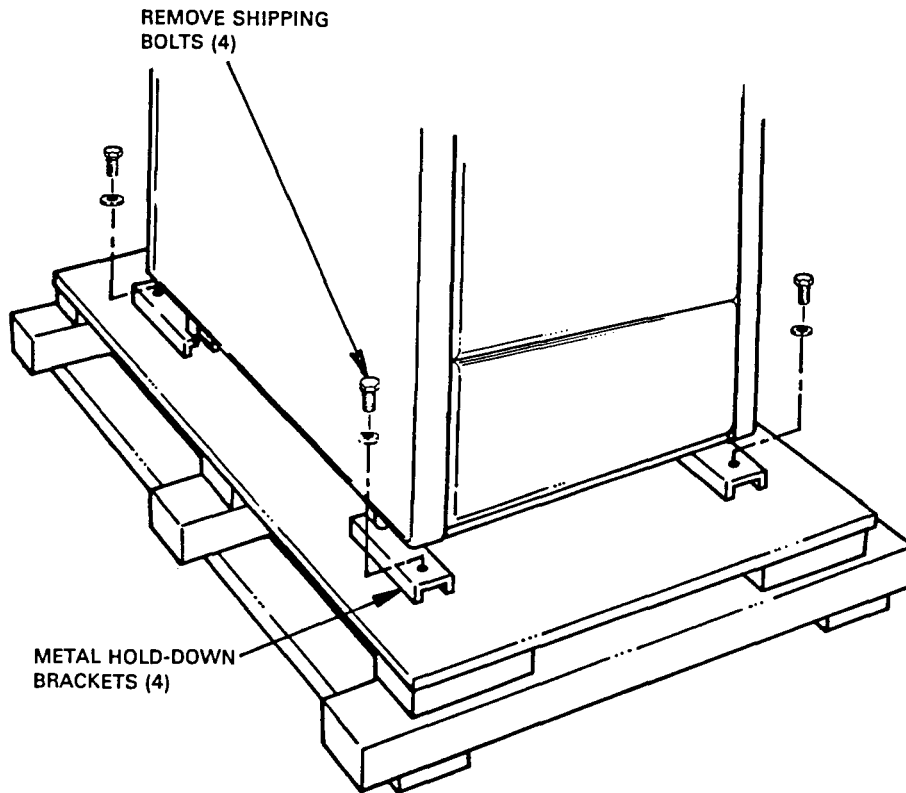

CS-2433

Figure 2-3 Cabinet Shipping Brackets

5. Using a 9/16 inch wrench, screw the leveling feet up into the cabinet base all the way.

CAUTION

Once the leveling feet are raised, the cabinet is free to roll on its casters. The cabinet is top-heavy and must be handled with care.

2.2.3 Deskidding the Cabinet

WARNING

Two people are required for moving the cabinet off the skid.

The recommended procedure for removing the tape transport cabinet from the skid is as follows:

1. One person stands in front of the cabinet while the other person stands behind it.
2. Grasp the cabinet by right top and by the left center, as shown in Figure 2-5.

1. TURN NUT DOWN TO BOTTOM.
2. SCREW FOOT INTO CABINET FAR ENOUGH TO PERMIT CABINET TO BE ROLLED ON ITS CASTERS.

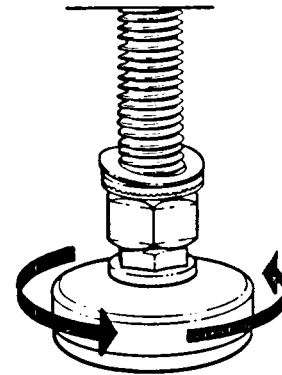
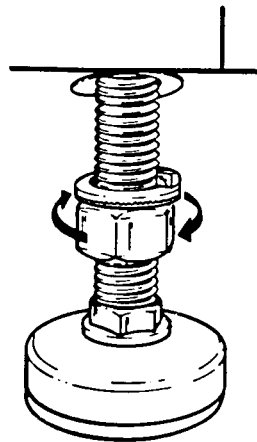

CS-2840

Figure 2-4 Raising Leveling Feet

3. Roll the cabinet off the side of the skid, taking care to prevent it from toppling over.
4. When the casters on the left side of the cabinet are on the floor, push the skid out from under the right side of the cabinet. Take care to prevent the cabinet from hitting the floor hard or toppling.
5. Open the rear door using a 5/32 inch hex key (see Figure 2-6) and verify that the envelope taped to the bottom of the cabinet contains:
 - a. 7008288-8F remote cable
 - b. 7422224/7422225 intercabinet hardware
 - c. Four 1/4-20 x 2.75 inch bolts
 - d. Twelve 1/4-20 self-retaining nuts

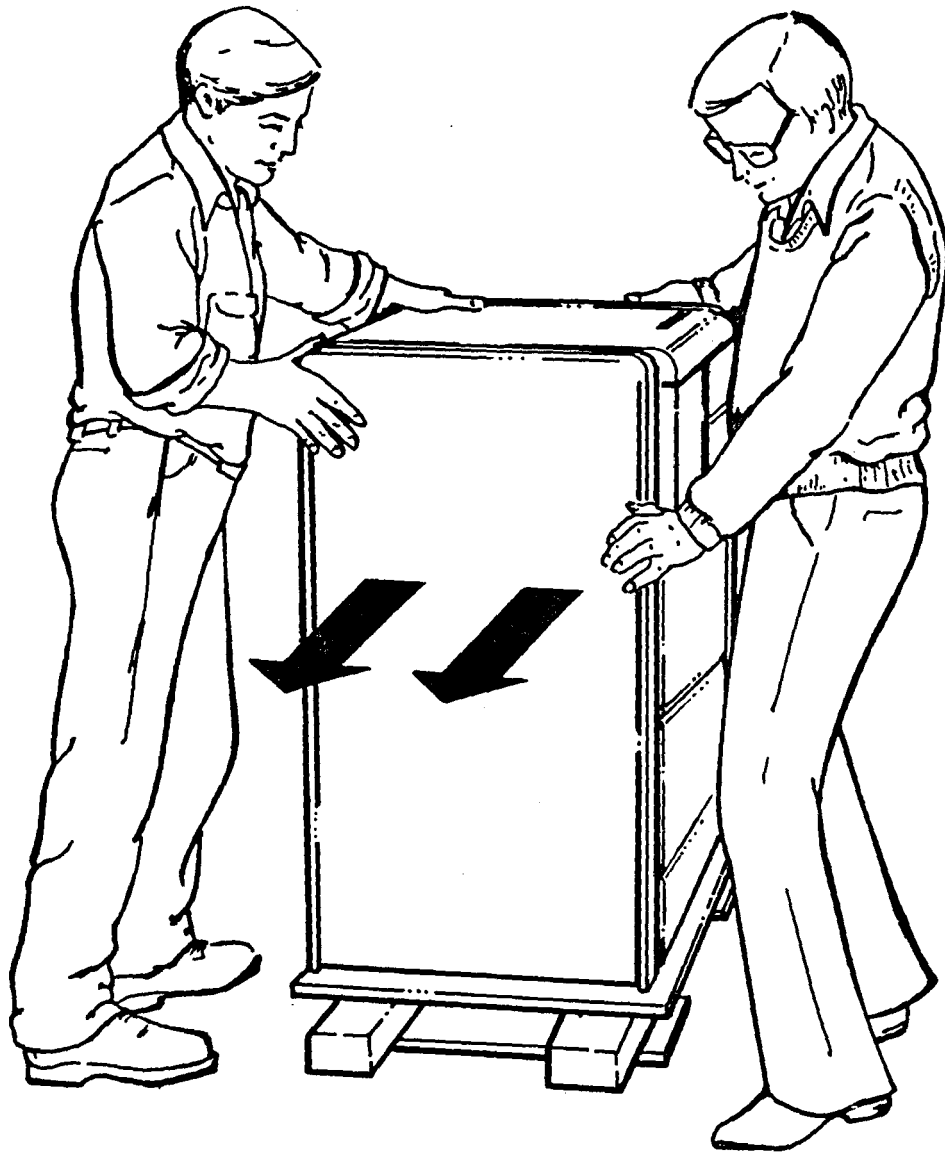

CS-2435

Figure 2-5 Deskidding the Cabinet

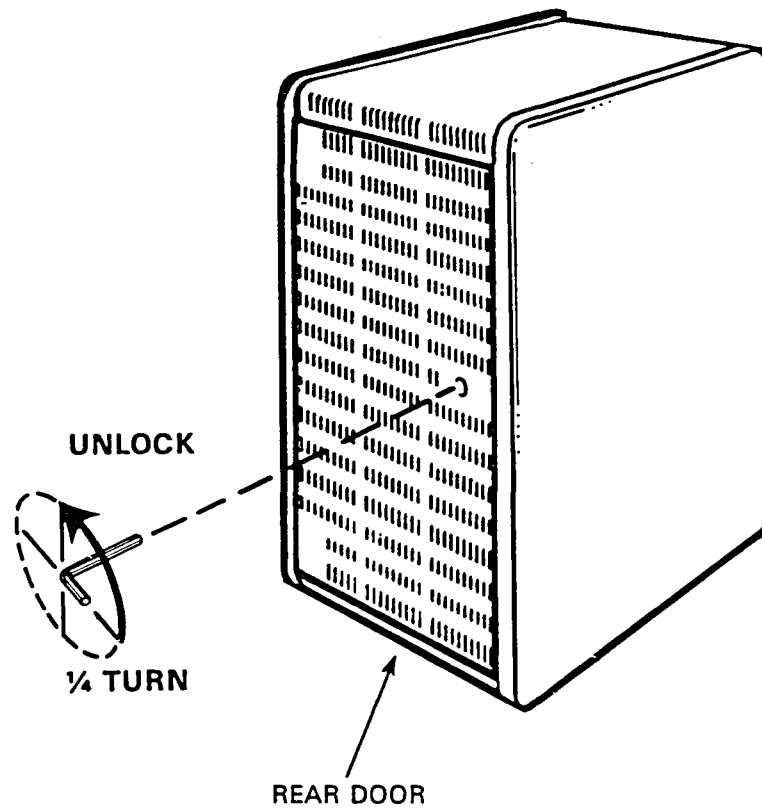

CS-2841

Figure 2-6 Opening Cabinet Door

2.2.4 Unpacking the Smaller Cartons

Open the smaller cartons and check that they contain the following:

1. M7196 bus interface/controller module
2. Two interconnection cables (part number 7016855-08)
3. TSV05 Tape Transport Installation Manual (EK-TSV05-IN)
4. TSV05 Tape Transport User's Guide (EK-TSV05-UG)
5. TSV05 Pocket Service Guide (EK-TSV05-PS)
6. 26.7 centimeter (10.5 inch) magtape number 30-18709-08
7. Tape cleaning kit part number TUC02
8. MP01157 print set.

Visually inspect each item. If any item is damaged, missing, or incorrect, contact the dealer from whom the system was purchased.

2.3 TAPE TRANSPORT CABINET INSTALLATION

In TSV05-A models, the tape transport is intended to be mounted in a user-supplied or separately-purchased cabinet. Refer to Appendix D for TSV05-A rack mounting guidelines.

In the TSV05-B model, the tape transport is shipped mounted in an H9642 cabinet that has no side panels but has an expansion ring on the right side. This cabinet is intended to be connected to the left side of an H9642 cabinet containing a PDP-11/23 or PDP-11/23+ computer (Figure 2-7).

The TSV05-B subsystem can also be connected to earlier LSI-11 computer systems that use H9612 cabinets. (Refer to Appendix E for H9612/H9642 cabinet interconnection procedures.) Note, however, that older systems were not tested for compliance with current FCC rules. Installing the TSV05-A or TSV05-B subsystems in cabinets other than the H9642 cabinet may result in higher levels of EMI radiation.

The TSV05-B tape transport cabinet is installed by moving the left side panel of the computer cabinet to the left side of the tape transport cabinet and then bolting the right side of the tape transport cabinet to the left side of the computer cabinet (Figure 2-7). This installation is described in the sections that follow.

2.3.1 Tools Required

Cabinet installation requires the following tools:

1. 9/16 and 11/16 inch wrench (for leveling feet)
2. 5/32 inch hex key (for door)
3. 7/16 inch wrench (for bolting cabinet together)
4. Screwdriver or nut driver, as applicable, for connecting ground cable.

2.3.2 Moving the Side Panel

Remove the left side panel from the computer cabinet and mount it on the TSV05 tape transport cabinet as follows:

1. Open the rear doors of the tape transport cabinet and computer cabinets. Typically, this requires inserting the hex key into the latch and turning it 1/4 turn counterclockwise. (See Figure 2-6.)
2. Remove the locking bracket located at the rear bottom, right-hand side (as viewed from the rear) of both cabinets. Each bracket is held by two bolts. Loosen but DO NOT remove the bolts (Figure 2-8).
3. Lift the side panel straight up and remove it from the CPU cabinet left side (Figure 2-8). Disconnect the side panel ground wire from the cabinet frame.

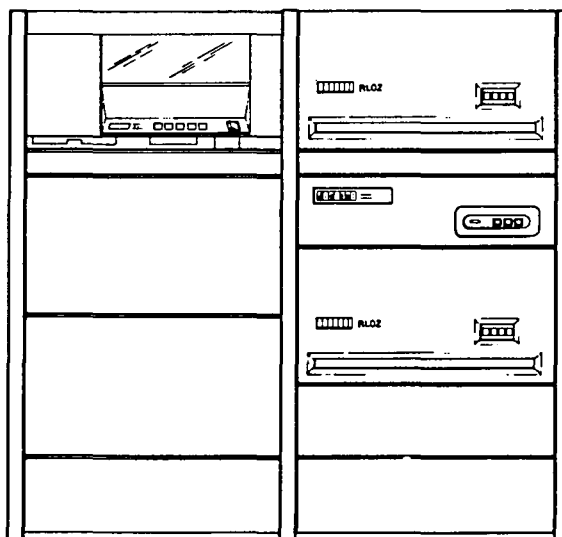
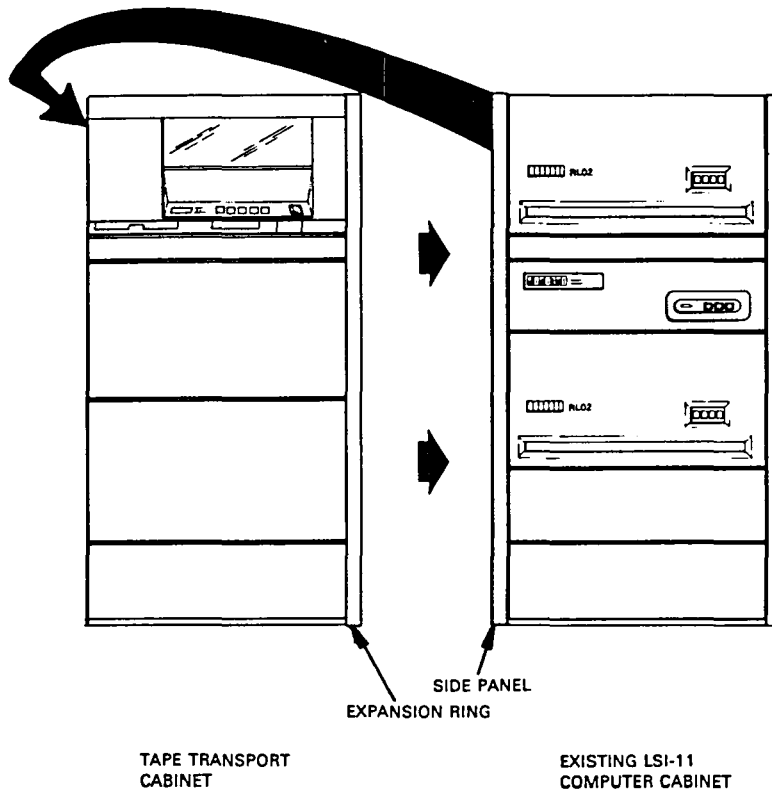

EXPANDED SYSTEM

CS-2436

Figure 2-7 H9642 Tape Transport Cabinet Connection

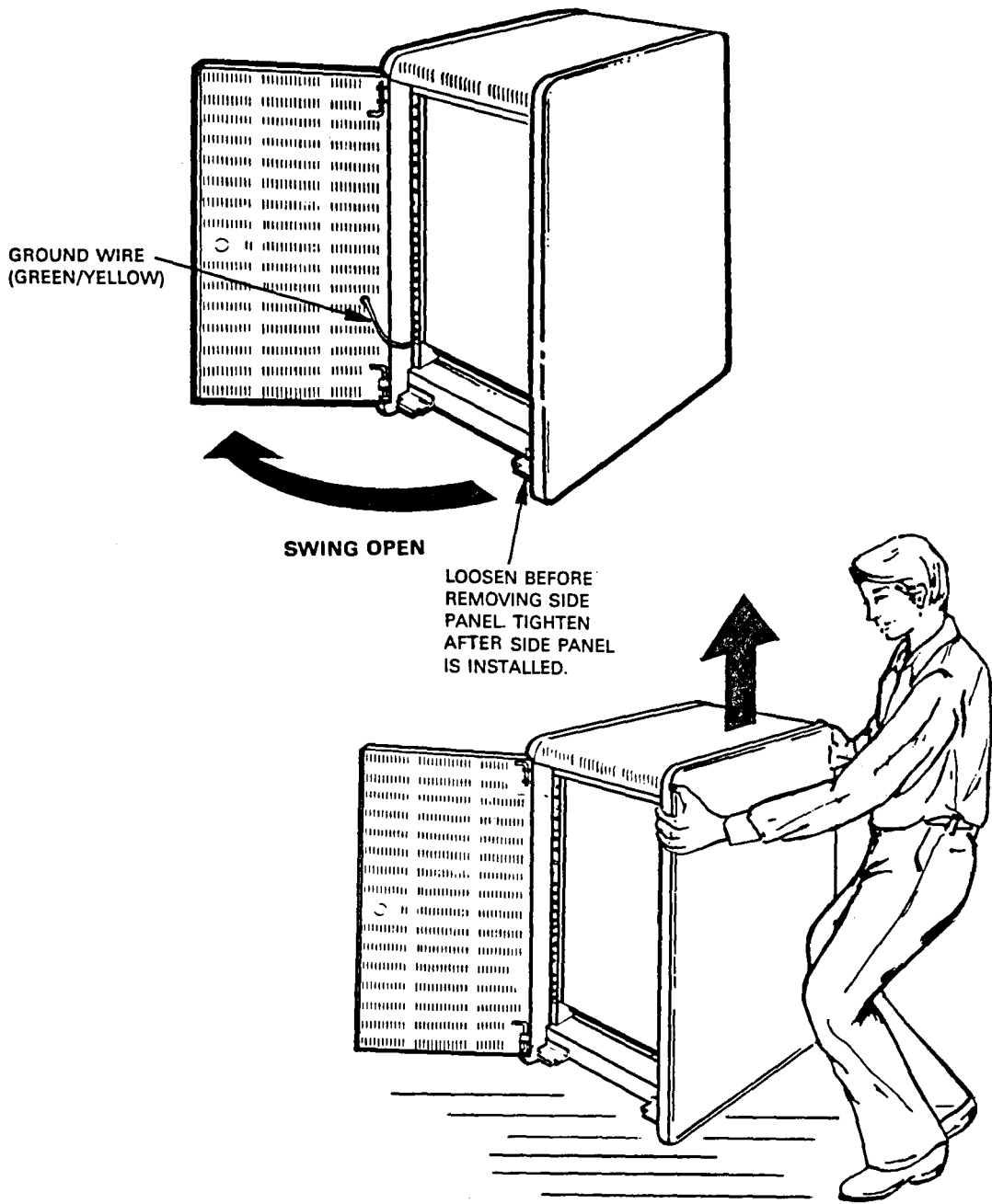
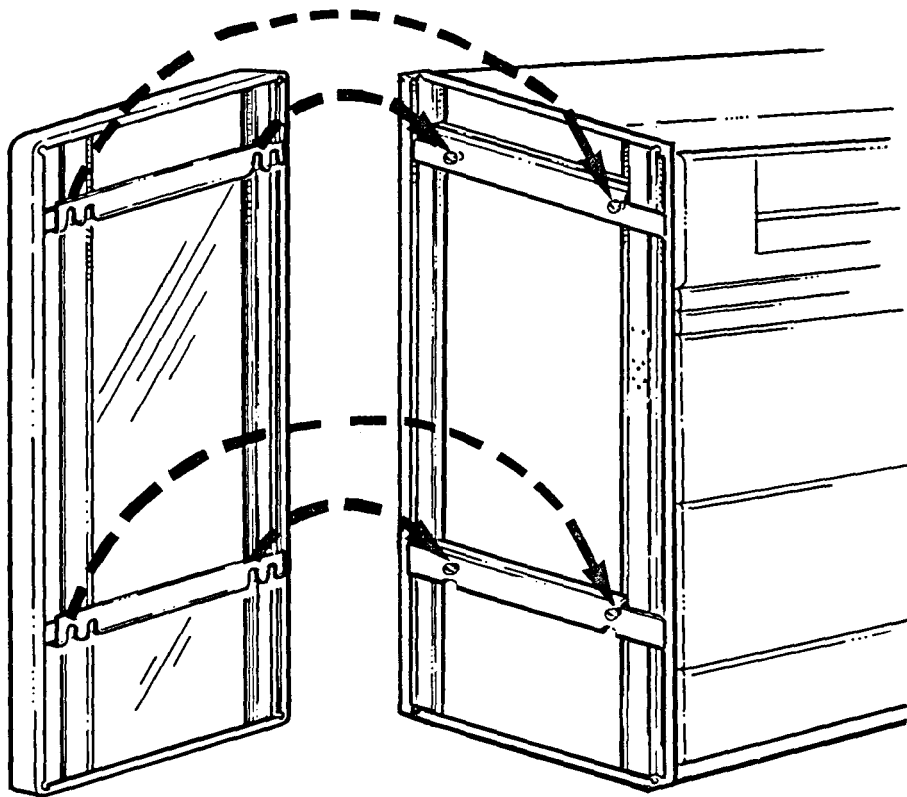
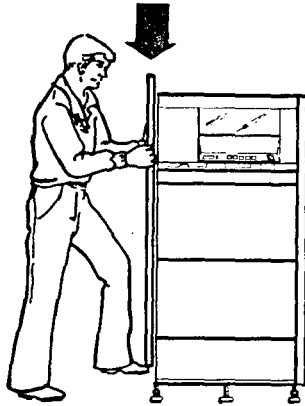

Figure 2-8 Removing Side Panel

4. Place the side panel removed in step 3 next to the tape transport cabinet left side. Connect the side panel ground strap to the tape transport cabinet using the hardware supplied on the left rear cabinet rail.
5. Position the side panel against the tape transport cabinet such that the slots align with the pins. (Refer to Figure 2-9.) Hold the side panel a few inches above its mounted position until it is even with the front and rear of the cabinet. Slide the panel straight down such that the four pins engage the four slots.
6. Reinstall and tighten the bracket located on the tape transport cabinet at the rear bottom right side. This was one of the brackets removed in step 2.



CS-2442

Figure 2-9 Mounting the Side Panel

2.3.3 Connecting the H9642 Cabinets

The two cabinets must be connected together both mechanically and electrically. The mechanical connection is made as follows:

1. Roll the tape transport cabinet, with side panel attached, next to the computer cabinet left side. Place the tape transport cabinet 2.5 centimeters (1.0 inch) forward of the computer cabinet such that the pins in the computer cabinet align with the cutouts in the expansion ring. To obtain this alignment, adjust the tape transport cabinet leveling feet until the top of the tape transport cabinet is level with the top of the computer cabinet.
2. Push the tape transport cabinet sideways so that it is against the computer cabinet. Push the tape transport cabinet backwards until it is even with the computer cabinet. Check that all the pins are engaged properly into the trim panel. (Refer to Figure 2-10.)
3. Reinstall the second locking bracket that was removed in Section 2.3.2, step 2. Do not tighten it. This bracket is located on the computer cabinet bottom rear, right-hand side. (Refer to Figure 2-11.)
4. Loosen, but DO NOT REMOVE, the locking bracket that holds the tape transport cabinet rear door bottom pivot pin. This is easier if you partially remove the rear door by pushing down on the top pivot pin and raising the rear door out of the bottom pivot hole.
5. Install the rear intercabinet bracket as shown in Figure 2-11. Tighten the four screws, ensuring all brackets are fully down. Reinstall the rear door if it was removed in step 4.
6. Remove the bottom trim panels located on the tape transport and computer cabinets. Typically, these panels are held in place by two phillips head screws.
7. Remove the four center-most bolts and two center-most trim panel brackets from the cabinetry.
8. Refer to Figure 2-11 and install the front intercabinet bracket. Reinstall the two trim panel brackets and tighten the four bolts, and then reinstall both bottom trim panels.
9. Recheck the cabinetry leveling. Adjust the leveling feet of both cabinets, if necessary, to ensure that the system is properly leveled and all leveling feet are properly supporting the system.

NOTE

The 1/4-20 nuts and bolts are not required for the H9642-to-H9642 cabinet installation.

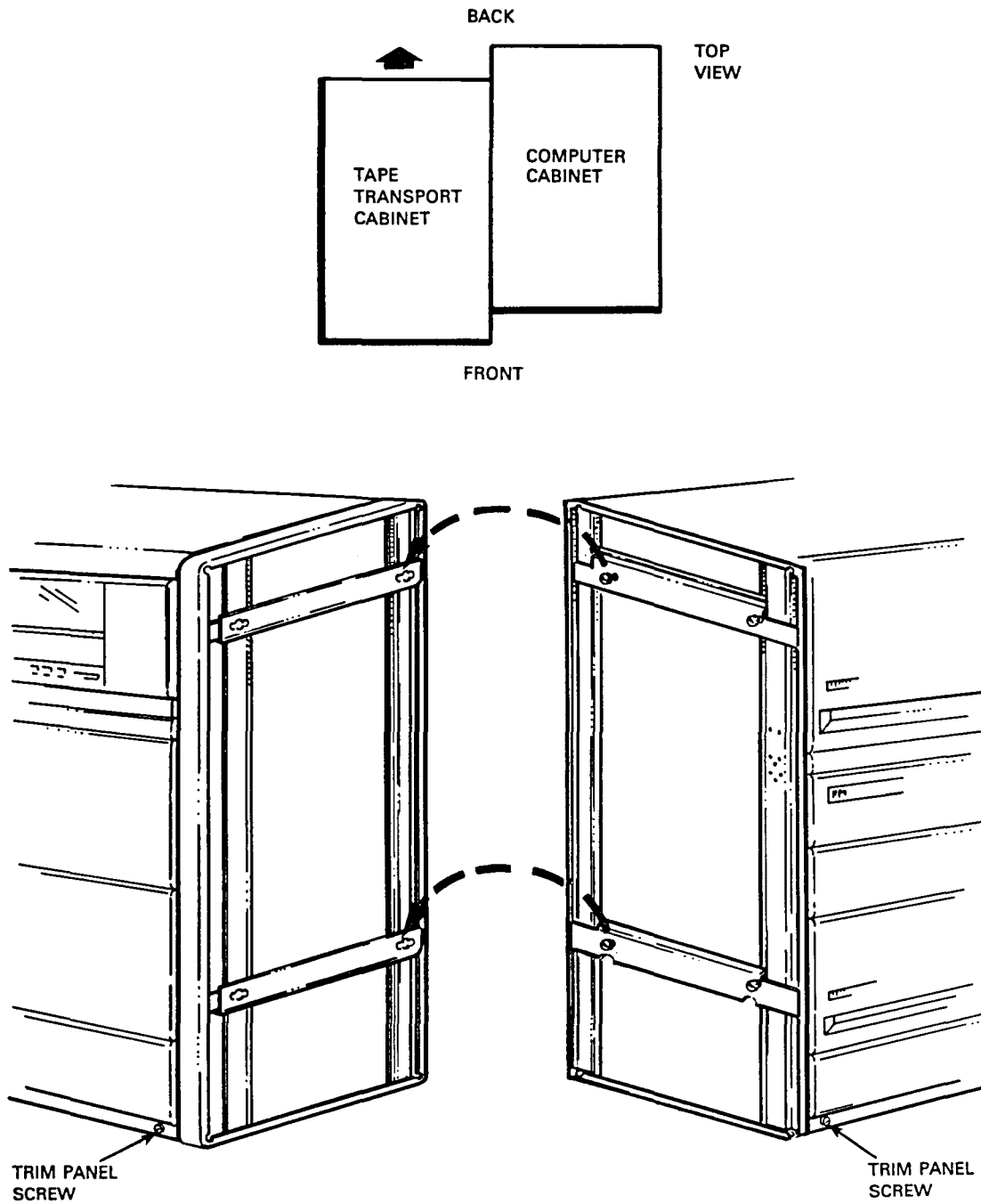

CS-2437

Figure 2-10 Cabinet Alignment

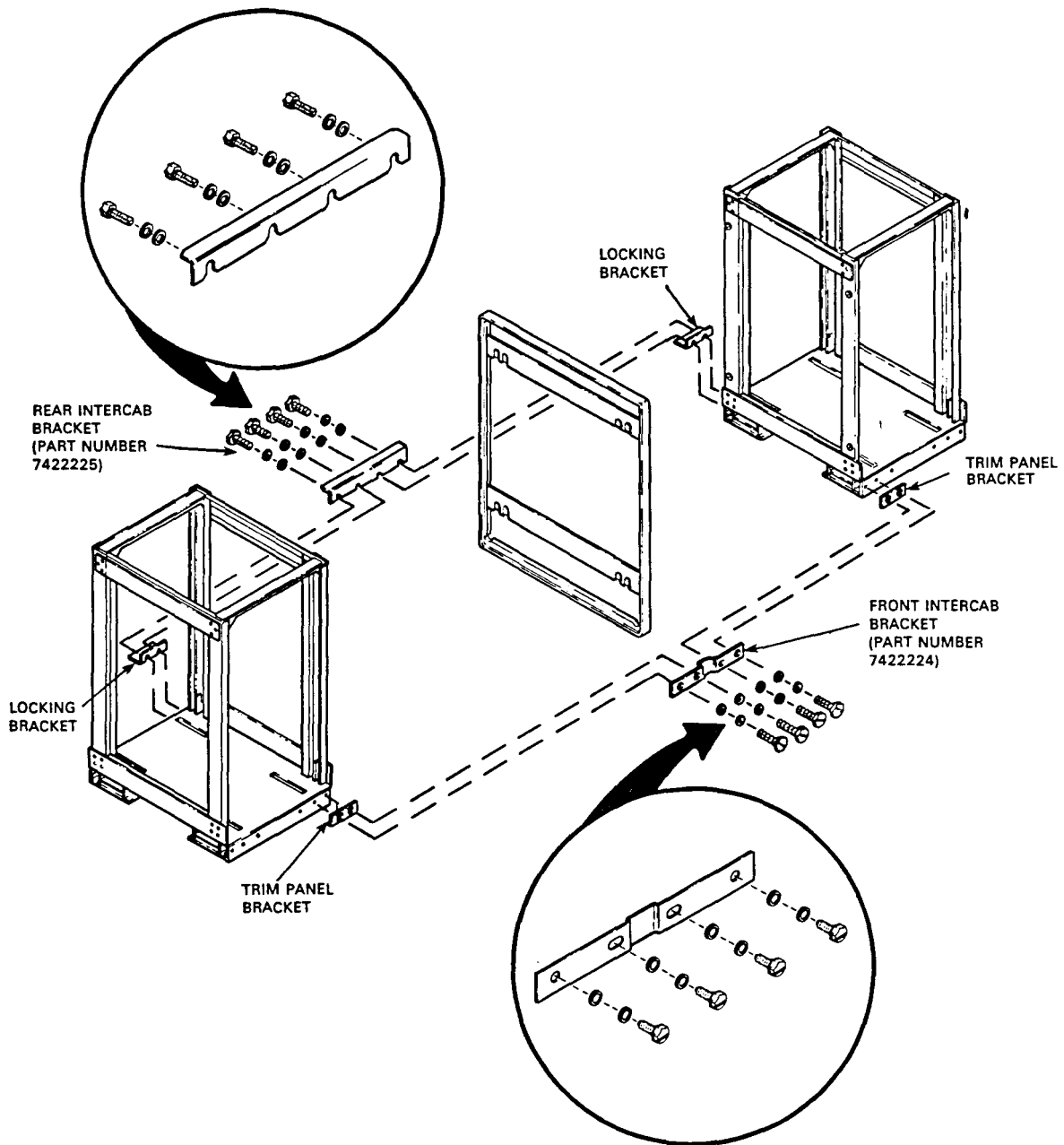

CS-2440

Figure 2-11 H9642 Cabinet Interconnection Hardware

2.3.4 Removing Shipping Foam

The tape transport is shipped with foam cushions protecting the takeup hub and blower motor. These cushions must be removed before the unit is powered up. This requires opening the tape transport to the operator maintenance access position to remove the foam from around the takeup hub, and opening it to the service access position to remove two other pieces of foam.

2.3.4.1 Removing the Top Foam Pieces

1. On TSV05-B models, raise the top of the cabinet by grasping the handle on the top cover and lifting. When the top cover is raised far enough, the support arm latches to keep the cover up. (Refer to Figure 2-12.)
2. Raise the top cover of the tape transport unit by reaching in through the front door and pushing upward on the front of the top cover. Prop the cover up using the nylon support that hangs from the left side of the cover. (Refer to Figure 2-13.)
3. Refer to Figure 2-14. Gently move the tachometer assembly away from the takeup hub. Remove the foam cushion. Carefully place the tachometer assembly back on the takeup hub.
4. Inspect and ensure that the tape path area is free of any foreign matter. With the cover still in the operator maintenance access position, proceed to Section 2.3.4.2.

2.3.4.2 Removing the Bottom Foam Pieces

1. Loosen the two spring-loaded captive screws, located on each side (as viewed from the top of the TS05 tape transport unit), that secure the TS05 unit to the top rail assembly. (See Figure 2-15.)
2. Lower the top cover of the tape transport unit.
3. With both hands, grasp the lower front of the TS05 unit and lift the entire assembly to its maximum upright position. (This engages the locking mechanism automatically.)

WARNING

Keep hands clear of corners of the tape unit while lifting. This is important to avoid brushing the mounting rails with your hands while lifting the unit.

- Carefully lower the TS05 unit approximately 2.5 centimeters (1.0 inch). (This will activate the locking mechanism automatically.)

WARNING

To eliminate the possibility of the tape unit dropping due to a failure in the locking mechanism, insert the supplied safety pin into the hole provided [2.5 centimeters (1.0 inch)] above the locking mechanism on the top plate supporting slide. Route the safety pin behind the supporting slide and across in front, and install it from left to right.

- Release the drive/formatter module by pulling down on the two NyLok™ fasteners that secure it to the bottom of the top plate assembly. When the NyLok fasteners are released, carefully lower the drive/formatter module as far as it will go.
- Remove the sheet and block of foam from the unit.
- Place the TS05 unit back to the operating position by reversing steps 1 through 5.
- Close the top cover of the tape unit and the top cover of the cabinet.

NOTE

To release the cabinet top cover support arm, it is necessary to raise the top cover slightly and move the top of the arm forward.

2.3.5 Connecting Line Power

TSV05-B models are equipped with cabinet power controllers. Before connecting the line power, perform the following checks: ■

- Power switch on the front panel of the tape transport is in the 0 (OFF) position.
- Power controller voltage rating is correct for your system.
- Power controller circuit breaker switches are in the OFF position.

NyLok™ is a trademark of NyLok Fastener Corporation.

4. Power controller LOCAL/REMOTE switch is in the LOCAL position.

With the switches in these positions, unwind the power cable and plug it into the receptacle.

2.4 TAPE TRANSPORT CHECKOUT

The tape transport is tested by itself before being cabled to the bus interface/controller module. This standalone testing is performed with the line power controlled locally at the cabinet power controller. After standalone operation has been verified, operation with the computer system is tested. At that point, the tape transport cabinet power is placed under the control of computer cabinet power controller by connecting the remote control cable. For the tests in this section, however, the remote control cable remains unconnected.

2.4.1 Power Up Test

1. Switch the circuit breaker switches on the cabinet power to the ON position. Observe that the power controller pilot lamp lights. Close the cabinet rear door.
2. On the tape transport front panel (Figure 2-16), press the power switch to the 1 (ON) position. Observe that all indicators light for approximately 2 seconds.
3. Observe that after 2 seconds all the indicators extinguish, and then the UNLOAD indicator lights.

If these indications have occurred, the tape transport unit has successfully completed the internal verification checks that it performs automatically at power up. If the indications were different, there is a problem. Refer to the TSV05 Pocket Service Guide or call your local Digital representative.

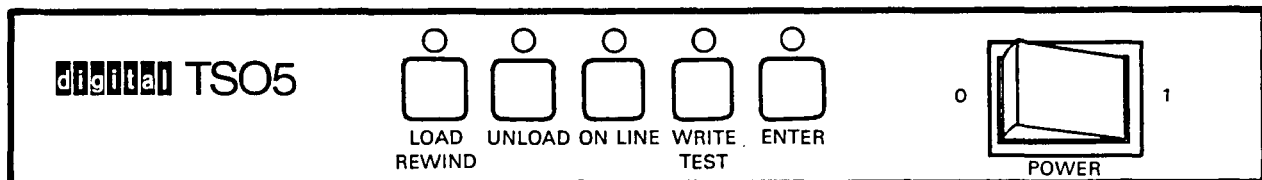

CS-2429

Figure 2-16 Front Panel Controls and Indicators

2.6.2 Power Controller Interconnection (Supplied With TSV05-B Models Only)

The power controllers in the two cabinets are to be interconnected by a remote control cable. This enables the computer cabinet power to switch on the tape transport cabinet power automatically whenever the computer is powered up.

The remote control cable, part number 7008288-8F, has a three-pin connector on each end. The cable connectors are the same, and they are keyed to plug in only one way. Refer to Figure 2-20 and install the remote control cable as follows:

1. In the computer cabinet, plug one end of the cable into the power controller connector labeled DEC POWER CONTROL BUS.
2. Route the remote control cable through the open side of the computer cabinet and into the tape transport cabinet. Do not route the cable outside the cabinetry.
3. In the tape transport cabinet, plug the cable into the power controller connector labeled DEC POWER CONTROL BUS.
4. Place the LOCAL/REMOTE switch in the REMOTE position.
5. Switch the circuit breaker switches to the ON position.

The tape transport cabinet power is now fully interconnected with the computer cabinet.

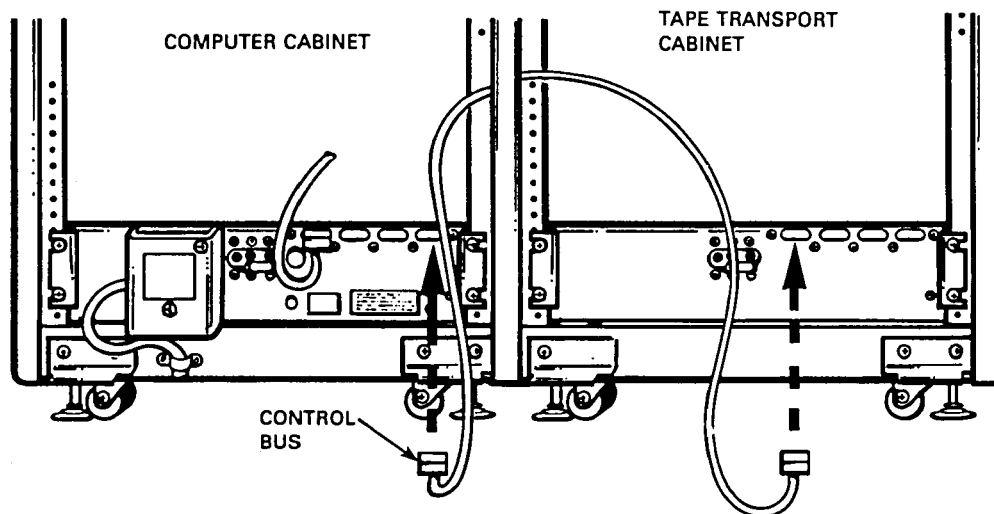

CS-2434

Figure 2-20 Remote Power Control Connections

2.7 TSV05 SUBSYSTEM CHECKOUT

The TSV05 subsystem is tested by checking the M7196 LED indicators and voltage supply, and by running the diagnostic programs listed in Table 2-2. These programs are available on the XXDP+ diagnostic software package that is shipped with the computer system. If your system is an earlier model and has the XXDP package instead of the XXDP+, contact your local Digital representative for ordering information.

2.7.1 Power Up Checks

1. Set the power switch on the tape transport unit to the ON position.
2. Switch on the computer system power and observe that the tape unit powers up with the system.
3. After a few seconds, all the tape unit indicators should be extinguished except for the the UNLOAD indicator.
4. Verify that the +5 V power to the M7196 module is within specification. Typically, the additional load of the M7196 module lowers the power supply voltage slightly. Adjust if necessary.
5. On the M7196 module, verify that the center LED (D2) is blinking. This indicates that the M7196 module self-test diagnostics are running. If other indications occur, there is a problem. Refer to the TSV05 Pocket Service Guide or contact your local Digital representative.
6. Replace the access panel on the computer and close the rear doors of the cabinets.

Table 2-2 TSV05 Subsystem Diagnostics

Program Title	File Name
Logic Test	CVTSAA
Advanced Logic Test	CVTSBA
Transport Test	CVTSCA
Advanced Transport Test	CVTSDA
Data Reliability Test	CVTSEA
DEC-X11	XTSAA0

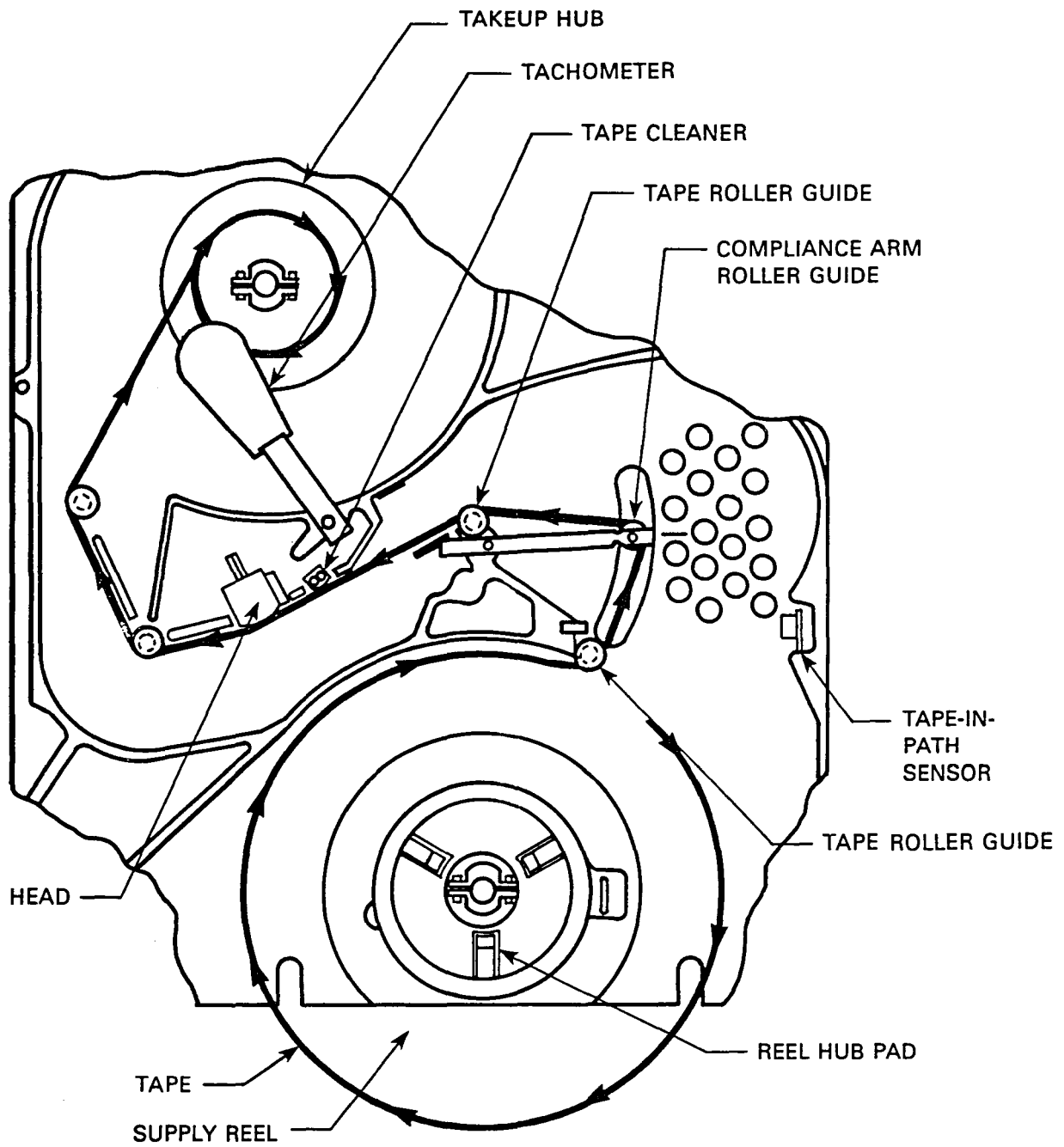

CS-2466

Figure 3-3 Tape Path and Related Parts

3. Tape Cleaner.

CAUTION

Exercise care to avoid damage to the sharp edges of the blades on the tape cleaner.

4. Roller guides (quantity of five)

NOTE

When cleaning the roller guides, the cleaning fluid should contact only the tape-bearing surfaces. This prevents degreasing the roller guide bearing.

5. Supply hub pawls (quantity of three)

6. Tape path. (use the supplied texwipes)

3.1.8.2.4 Cleaning the Housing -- Clean the front panel door and the control panel with Miller Stephenson Chemical Company MS-260, Windex™, or an equivalent commercial grade plastic cleaner and a clean, lint-free wipe material.

3.2 TSV05 OPERATIONS

The TSV05 is compatible with TS11/TS04 software in all operating system level functions. Generally, any utility that supports a magtape subsystem (device code MS) supports the TSV05. For detailed procedures and examples, refer to the utilities manual for your operating system.

Operation of the TSV05 may differ slightly from that of the TS11/TS04 at the level of user-written application programs. Refer to Section 3.3. for detailed descriptions of program-accessible TSV05 functions.

3.3 PROGRAMMING

The TSV05 follows the same programming protocol as the TS11/TS04 subsystem. The nature of the TS05 transport dictates that some status bits will be redefined. In addition, the TSV05 has special features not available in the TS11/TS04 subsystem.

Windex™ is a trademark of The Drackett Products Company.

Table 3-5 TSSR Register Bit Definitions (Cont)

Bit	Name	Code	Definition
03-01	TC<2:0>	S	<p>Termination Class Code - This 3-bit field acts as a word offset value whenever an error or exception condition occurs on a command. Each of the 8 possible values of this field represents a particular class of errors or exceptions. The conditions in each class have similar significance and recovery procedures (as applicable). The codes are:</p> <p><u>Code Meaning</u></p> <ul style="list-style-type: none"> 0 Normal Termination 1 Attention Condition 2 Tape Status Alert 3 Function Reject 4 Recoverable Error - tape position is one record down tape from start of function. 5 Recoverable Error - tape not moved 6 Unrecoverable Error - tape position lost 7 Fatal Controller Error - (See Fatal Class Codes)
0	-	-	Not Used

3.3.2.4 Extended Data Buffer Register (TSDBX) -- The Extended Data Buffer Register (TSDBX) is a Write-Only hardware byte register located at the fourth byte address of the TSV05 I/O register block. This address corresponds to the high-order byte of the TSSR register. The TSDBX is used to specify the most significant four bits of a 22-bit command pointer address, and also to allow an automatic tape boot sequence to be performed. TSDBX can be written only by a byte-access (DATOB) cycle addressed to the high byte of TSSR. If the Extended Features switch is Off when TSDBX is written, only the boot bit is examined; the other bits are ignored.

Figure 3-8 illustrates the format of TSDBX, and Table 3-6 describes each bit.

Assume the Extended Features switch is on. Once written, the contents of the least-significant four bits of TSDBX are transferred to bits 18 through 21 of the internal TSBA (Bus Address) register for use as a command pointer. The low order 18 bits of the command pointer are specified by writing into the TSDB register, which starts operation and then clears TSDBX. Therefore, a subsequent load of only the TSDB will specify a 22-bit command pointer address with the high-order four bits equal to zero. For the TSDBX register to be properly written, the SSR (Subsystem Ready) bit in TSSR must be set; if it is not, the RMR (Register Modification Refused) bit will be set and no modification to TSDBX will occur. When the TSDBX is written, the SSR bit is not cleared. Therefore, RMR should be checked for, before TSDB is written. Writing the TSDB will begin processing on TSDBX. If the Boot bit is not set, the command pointed to by the 22-bit TSDB will be retrieved, and command processing will begin. If the Boot bit is set, SSR will remain clear until the boot sequence is complete or until an error occurs.

LSI-11 Bus Bits:	15	14	13	12	11	10	9	8
Byte Data Bits:	7	6	5	4	3	2	1	0

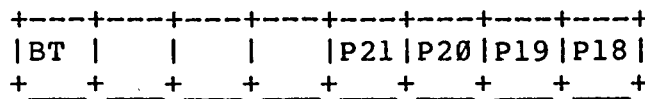

Figure 3-8 TSDBX Register Format

Table 3-13 Message Packet Field Definitions

Word	Bit	Description																					
1 (Header)	15	ACK -- Acknowledge. This bit is set by the TSV05 to inform the CPU that the Command Buffer is now available for any pending or subsequent command packets. On an ATTN message, this bit will not be set since the controller does not own the Command Buffer.																					
	14-12	Reserved. These bits are reserved for future expansion. They will always appear as zero.																					
	11-8	Class Code Field. These bits define the class of failure determined for the rest of the message buffer when the Message Type field is not indicating a normal END message. The codes are:																					
		<table border="1"> <thead> <tr> <th>Message Type</th> <th>Class Code</th> <th>Definition</th> </tr> </thead> <tbody> <tr> <td>ATTN</td> <td>0000</td> <td>On or off line</td> </tr> <tr> <td>ATTN</td> <td>0001</td> <td>Microdiagnostic failure</td> </tr> <tr> <td>FAIL</td> <td>0000</td> <td>Not used. (On the TS11, this code indicates a Bad Packet due to a serial bus parity error.)</td> </tr> <tr> <td>FAIL</td> <td>0001</td> <td>Illegal Command (ILC), Illegal Address (ILA), or Need Buffer Address (NBA) on a tape motion command.</td> </tr> <tr> <td>FAIL</td> <td>0010</td> <td>Write-Lock error on Non-executable function.</td> </tr> <tr> <td>FAIL</td> <td>0011</td> <td>Microdiagnostic Error.</td> </tr> </tbody> </table>	Message Type	Class Code	Definition	ATTN	0000	On or off line	ATTN	0001	Microdiagnostic failure	FAIL	0000	Not used. (On the TS11, this code indicates a Bad Packet due to a serial bus parity error.)	FAIL	0001	Illegal Command (ILC), Illegal Address (ILA), or Need Buffer Address (NBA) on a tape motion command.	FAIL	0010	Write-Lock error on Non-executable function.	FAIL	0011	Microdiagnostic Error.
	Message Type	Class Code	Definition																				
	ATTN	0000	On or off line																				
	ATTN	0001	Microdiagnostic failure																				
FAIL	0000	Not used. (On the TS11, this code indicates a Bad Packet due to a serial bus parity error.)																					
FAIL	0001	Illegal Command (ILC), Illegal Address (ILA), or Need Buffer Address (NBA) on a tape motion command.																					
FAIL	0010	Write-Lock error on Non-executable function.																					
FAIL	0011	Microdiagnostic Error.																					
7-5	Packet Format #1 Field. The single value supported by the TSV05 is 000, which specifies a one-word message header.																						

Table 3-13 Message Packet Field Definitions (Cont)

Word	Bit	Description															
1	4-0	<p>Message Type Code. This field, together with the Format field indicates the format and length of message packets. For the TSV05 (and TS11), the Message Type is of the form 10xxx, which indicates that the message contains a Header word, a Data-Cont'd Length word and then xxx Data/Status words. This field indicates the general type of message contained in the buffer and is related to the Termination Class Code appearing in the TSSR register as follows:</p> <table border="1"> <thead> <tr> <th><u>Termination Class Code</u></th> <th><u>Message Type</u></th> <th><u>Definition</u></th> </tr> </thead> <tbody> <tr> <td>0,2</td> <td>10000</td> <td>End</td> </tr> <tr> <td>3</td> <td>10001</td> <td>Fail</td> </tr> <tr> <td>4,5,6,7</td> <td>10010</td> <td>Error</td> </tr> <tr> <td>1,7</td> <td>10011</td> <td>Attention</td> </tr> </tbody> </table>	<u>Termination Class Code</u>	<u>Message Type</u>	<u>Definition</u>	0,2	10000	End	3	10001	Fail	4,5,6,7	10010	Error	1,7	10011	Attention
<u>Termination Class Code</u>	<u>Message Type</u>	<u>Definition</u>															
0,2	10000	End															
3	10001	Fail															
4,5,6,7	10010	Error															
1,7	10011	Attention															
2 (Data Length)	15-8	Reserved. This field is reserved for future expansion. It always appears as 0.															
	7-0	Data Field Length. This field specifies how many bytes of information follow this word in the message packet. Normally, with the Extended Features option of the TSV05 disabled, this field contains a value of 12 (binary 00001010), indicating that the packet contains the RBPCR plus four Extended Status registers. With the Extended Features option enabled, this field contains a value of 14, to indicate that an additional Extended Status register (XST4) is supplied.															

APPENDIX D
TSV05-A RACK MOUNTING GUIDELINES

The TSV05-A is designed to be mounted in an Electronic Industries Association (EIA) standard 19 inch wide equipment rack with RETMA standard hole spacing (5/8 inch, 5/8 inch, 1/2 inch). The TSV05-A includes mounting slides designed for 5/8 inch hole spacing. Additionally, it is shipped with a locking shipping bracket and hardware designed to fit H9642 cabinetry. The recommended procedure for rack mounting the TSV05-A is as follows:

1. Unpack and inspect the tape transport unit. It is shipped in the largest of the cartons. Unpack, inspect, and inventory the contents of the smaller cartons as described in Section 2.2.4.
2. Remove the sliding parts of the tape transport chassis mounting slides by extending them to the rear of the tape transport. This requires disengaging the safety latches.

CAUTION

The left and right mounting slides are not interchangeable. The safety latches do not engage properly if the slides are reversed.

3. Refer to Figure D-1 and to the equipment rack and determine the desired rack elevation for mounting the slides. Items to consider when selecting the mounting location include:
 - a. Power cord length is 2.4 meters (8.0 feet).
 - b. Interface cable length is 2.4 meters (8.0 feet).
 - c. The equipment rack must be stable when the TSV05-A is fully extended on the slides for servicing.
 - d. The TSV05-A should not be mounted close to high heat sources.
 - e. A 1.75 inch trim strip can be purchased from Digital (part number H9544-DA). This trim strip can be added to the tape transport to obtain a combined height of 10.5 inches. This vertical dimension is standard for many racks.
4. Using four 10-32 x 3/8 inch bolts for each slide, secure the slides to the equipment rack at both the front and rear mounting holes (Figure D-2). Note that the slides mount to the rear of the front cabinet rail.

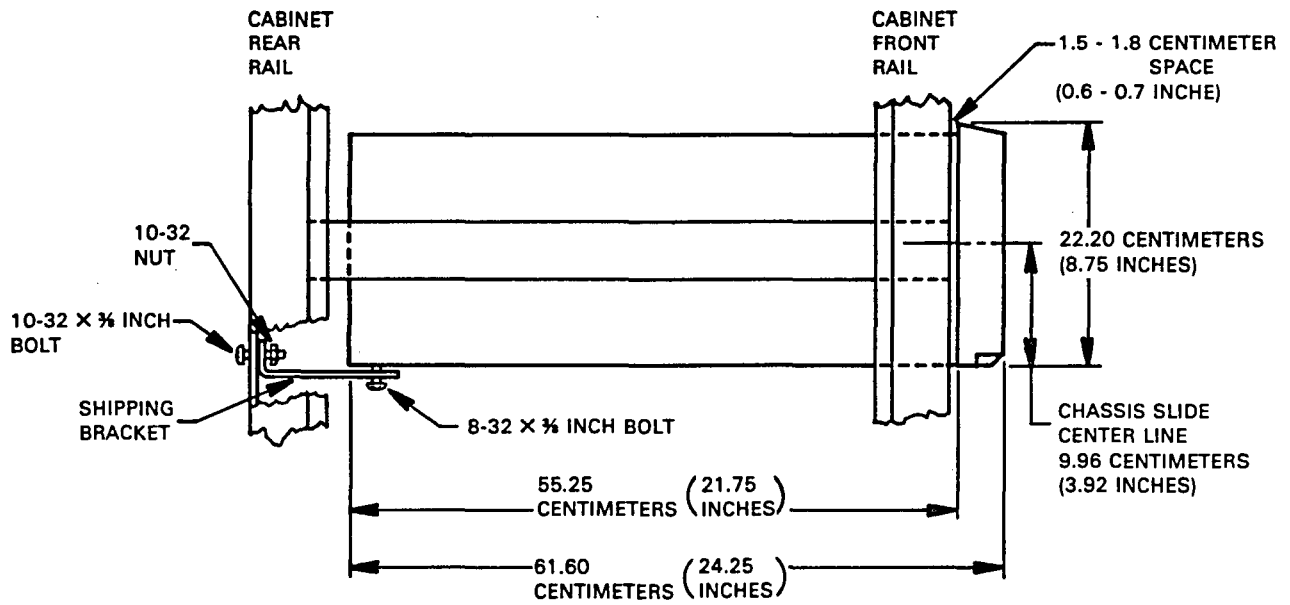

SIDE VIEW

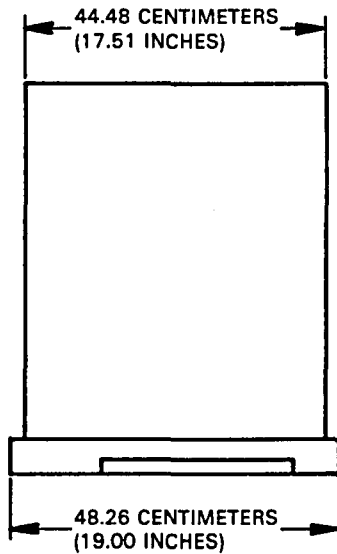

TOP VIEW OF TAPE TRANSPORT

CS-2851

Figure D-1 TSV05-A Mounting Requirements

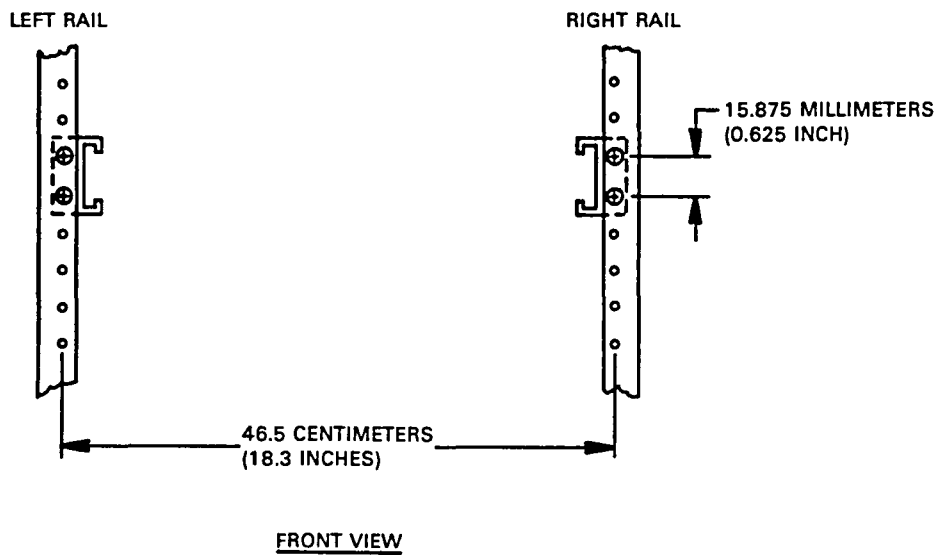
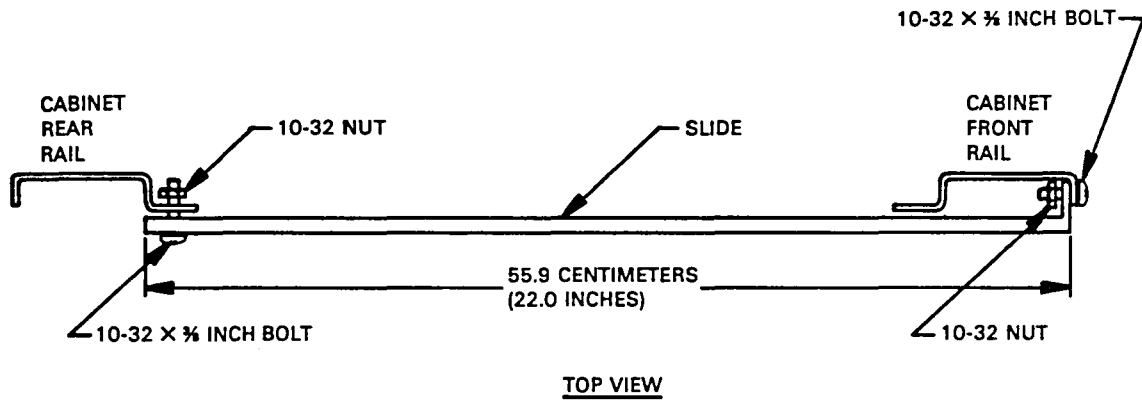

CS-2852

Figure D-2 Chassis Slide Mounting

5. Fully extend the center sections of the slides now secured to the rack. When a slide is fully extended, the latch clicks as it locks the slide in its extended position.
6. The tape transport unit should now be slid into the rack mounting slides.

WARNING

Two people are required for sliding the tape transport unit into the rack.

With one person on each side, lift the transport and insert the slides on the transport into the slides mounted in the rack. Depress the spring latches located on the transport slides and push the transport into the rack until the latches lock into place. This is approximately 8 centimeters (3 inches). Then depress the spring latches a second time and push the transport fully into the rack. A gap of approximately 1.5 to 1.8 centimeters (0.6 to 0.7 inch) is normally present between the rear of the transport front bezel and the mounting rail.

7. Locate the shipping bracket packed with the TSV05-A. The bracket is designed for use on Digital H9642 series cabinetry, and secures the tape transport unit to the rear cabinet rail (Figure D-1). Install the shipping bracket to protect the equipment during shipment. It is recommended that similar protection be provided by other types of cabinetry.
8. Connect the tape transport power line to the cabinet power receptacle. Refer to Section 2.1.2 for power requirements. For the most reliable operation, the use of filtered ac line voltage is recommended. Make certain there is sufficient power cord slack for the TS05 tape transport to be placed in the service access position without damaging the power cord.
9. Remove the shipping foam from the tape transport as described in Section 2.3.4.
10. Continue the checkout and installation procedures as described Sections 2.4 through 2.7.

APPENDIX E
H9612 TO H9642 CABINET INTERCONNECTION

This cabinet interconnection procedure can be used for installations that meet the following conditions:

1. The system uses a PDP-11/23A computer.
2. The computer cabinet is model H9612.
3. The computer cabinet has pop-out type end panel inserts.
4. The cabinet has four adjustable leveling feet capable of raising it 13 millimeters (1/2 inch).
5. There is no external hardware connected to the cabinet that would be adversely affected by being raised 13 millimeters (1/2 inch).

If these are true, then the H9642 tape transport cabinet can be connected to the H9612 computer cabinet as follows:

1. Remove the left side pop-out end panel and ground strap from the H9612 computer cabinet. These parts are reused in step 5.
2. Remove the expansion ring from the right side of the tape transport cabinet. Note that this requires loosening the rear bottom locking bracket. The expansion ring is reused in step 5.
3. Place the tape transport cabinet next to the left side of the computer cabinet. Typically, the computer cabinet will be approximately 13 millimeters (1/2 inch) lower than the tape transport cabinet at this point.
4. Adjust the computer cabinet leveling feet until the top of both cabinets are even.
5. Assemble the pop-out end panel insert (removed in step 1) with the expansion ring (removed in step 2) to make a finished end panel suitable for mounting on the tape transport cabinet. This is done as follows:
 - a. Place the end panel insert into the expansion ring on the nonslotted side.
 - b. Align the positioning inserts.
 - c. Using a flat-blade screwdriver, pop the spring tabs into place.

NOTE

An assembled end panel (part number H9544-AA) can be purchased from Digital.

6. With both cabinets level and even, install the 4 bolts and 12 nuts at convenient locations to connect the two cabinets (Figure E-1). Note that the 7422224/7422225 intercabinet brackets are not used in this installation.

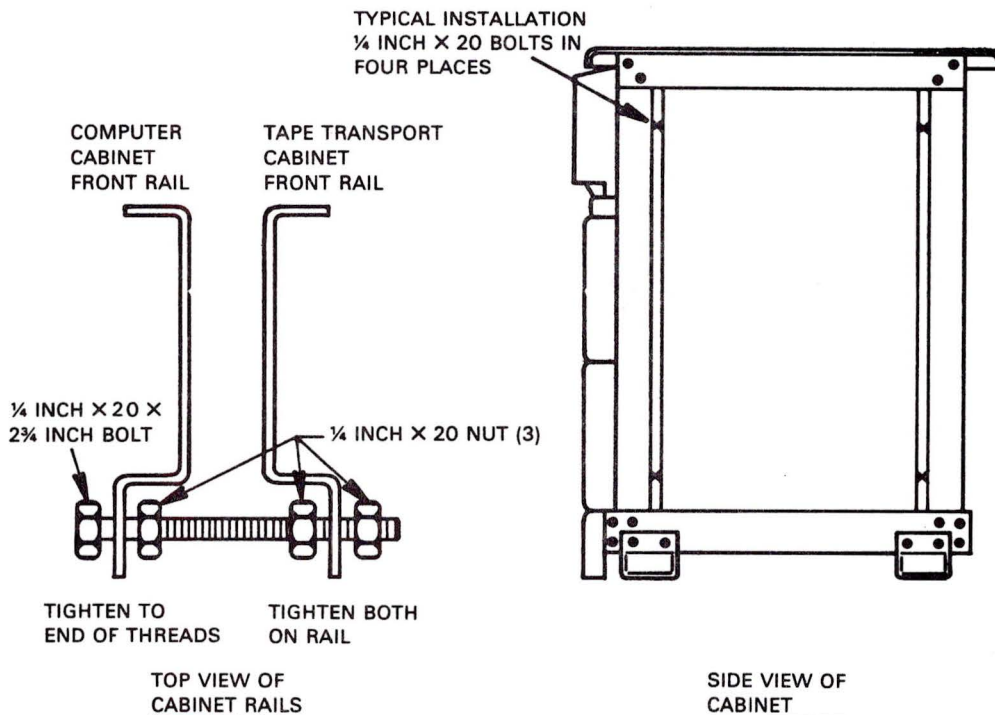

CS-2853

Figure E-1 Cabinet Interconnection

7. Place the assembled side panel next to the left side of the tape transport cabinet. Using the supplied hardware, connect the side panel ground strap to the tape transport cabinet left rear cabinet rail.
8. Install the assembled side panel on the tape transport cabinet (refer to Figure 2-9). Note that the rear bottom locking bracket must be loosened to perform this step.
9. Recheck the cabinet leveling. If necessary, adjust the leveling feet of both cabinets to ensure that the system is level and that all leveling feet are supporting the system properly.
10. Ensure that the locking brackets loosened in steps 2 and 8 are tightened securely.

11. Continue with the installation by removing the foam shipping cushions, as described in Section 2.3.4, and making the necessary power line connections, as described in Section 2.3.5.

